

Leadership in fusible circuit protection



EATON

Powering Business Worldwide

Eaton has over 100 years of experience in the design and manufacture of fuse links.

As the automotive world is becoming ever more electrified the power requirements are changing, so have the protection needs. Eaton is continually developing designs to meet these ever changing requirements.

The experience of Eaton in protecting semiconductor devices has proved invaluable as vehicle powertrain systems have moved to power based converters for the variable speed motor drives and also for auxiliary power conversion.

This application guide has been developed using the knowledge obtained from developing fuse links for the automotive industry in recent years across a variety of applications in a multitude of locations.



Table of contents

Eaton's Bussmann series Hybrid and Electric Vehicle capability overview	4 - 5
Introduction	6
Industrial vs EV applications	6
Voltage and current dimensioning	7
Fuse link selection criteria	8 - 11
Basic selection	8
Temperature derating	8
Thermal connection derating	8
Cooling air correction	8
High altitude derating	9
Enclosure correction factor	9
Cyclic loading	9
Influence of overloads	10
Coordination with relays and other protection components	10
Fuse selection	10
Worked example	11
Automotive standards and qualification	12

**Charge inlet AC or
Quick charge inlet DC**

Lithium-ion battery

Power-control unit

On-board charger

Electric motor

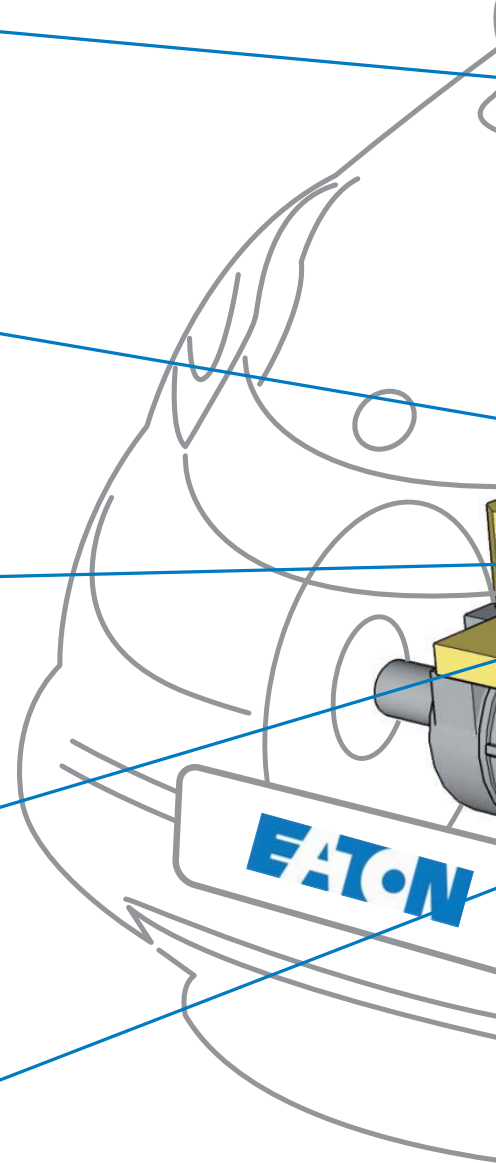

Typical fuse links applications in

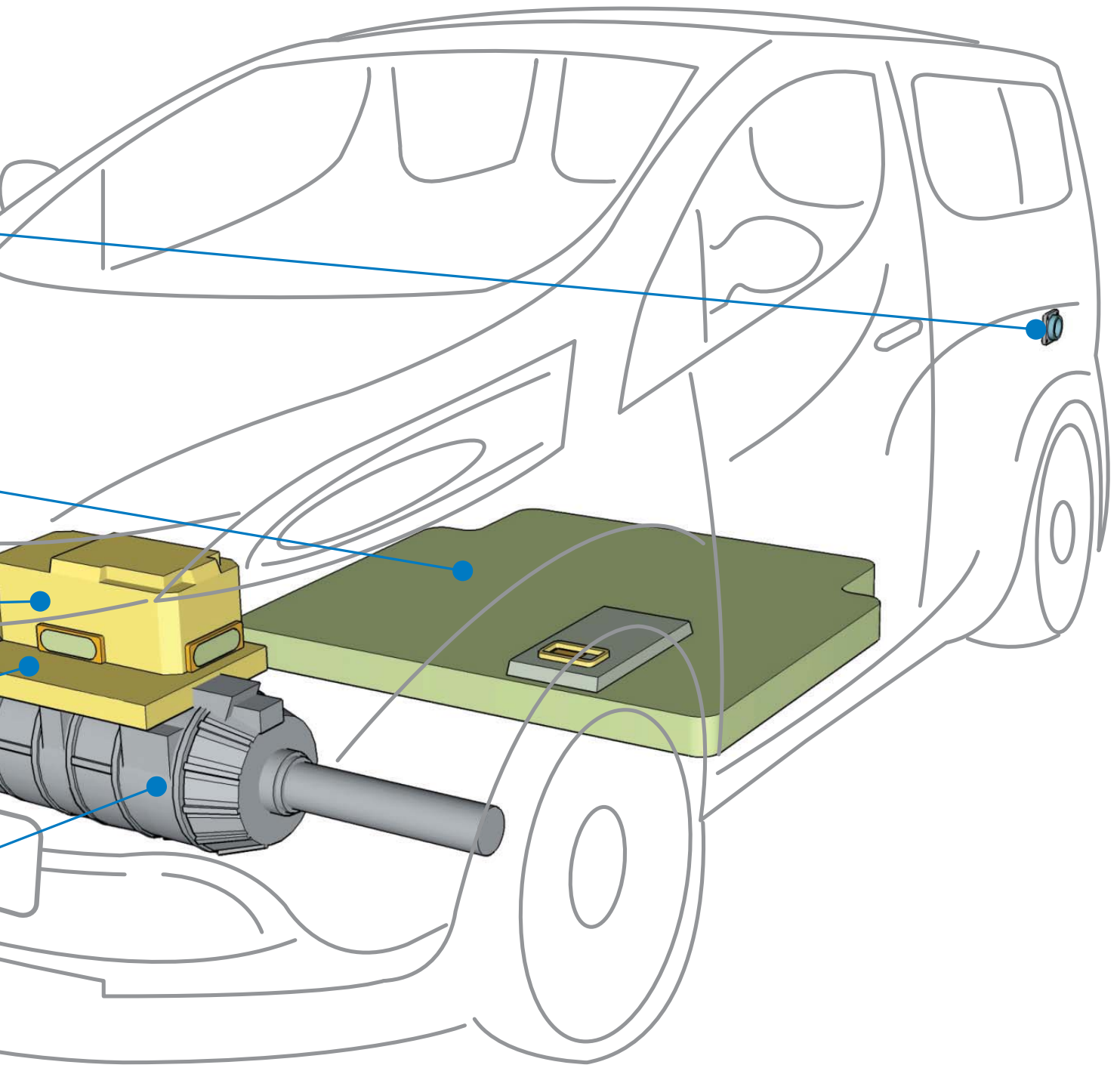

a Hybrid and Electric Vehicle (HEV)

Introduction

With an estimated 20 million electric vehicles set to hit the road worldwide by 2020 [1] [2] there is an increasing expectation for component manufacturers to respond to the challenging demands placed on them by leading car manufacturers.

As market acceptance of electrified vehicles builds, industry experts as well as OEM platform forecasts are predicting strong growth in vehicle sales leading up to 2020. Figures show that in EMEA alone there will be more than 800,000 vehicles built to satisfy this changing demand [3]. The unique and dynamic environment of the electric vehicle places additional and often unknown stresses on internal electrical components pushing industrial components beyond their capabilities.

Through this application guide we will explore the continued design challenges we face as we continue to see flaws in the use of industrial fuse links in Hybrid and Electric Vehicles (HEV) applications.

Industrial vs EV applications

Electrical fuse links have been in use since the earliest days of electric telegraph and power distribution protection. Since their conception electrical fuse links have been subject to ongoing development to meet the ever changing application uses, for example cable protection, transformer protection to switches, batteries, photovoltaic (PV) and rail systems. The arrival of HEV applications brings with it new set of design challenges for fuse links, with each application having varying requirements, an in-depth understanding of the environmental parameters and typical drive cycle profile is key to selecting a suitable fuse link for such a demanding environment.

Industrial fuse links are designed and tested to known standards IEC 60269 and UL 248. The behaviour of fuse links in conditions applicable to these industrial standards have been researched and understood drawing conclusion to derating considerations in environments where fuse links are subject to conditions differing from the standard. The challenge in EV applications is that the conditions are often outside the researched behaviours or even outside the requirements of the standard itself.

This application guide details the essential environmental and electrical considerations, to select an appropriate fuse link for electric vehicle protection.

[1] Phil Skipper, "Electro mobility – The opportunity", BEAMA Low Carbon Living Conference, Mar 2011

[2] Dr Kim Wakelin "Fuse link-link protection in the challenging and extreme conditions of HEV environments" ICEFA Conference, September 2015

[3] ACEA/AEB Passenger car registrations report March 2016

Voltage and current dimensioning

Voltage dimensioning

Traditional automotive batteries were mostly lead-acid batteries rated at 12 V d.c., 24 V d.c. or 42 V d.c. Today however, EV batteries are moving to Lithium-Ion and can range from 150 V d. c. to 800 V d.c. as car manufacturers strive to improve their vehicles power, range and charging time. In EV applications, electrical fault conditions can reach as high as 950 V d.c. and components must be able to operate safely at this voltage level. This is a particularly important requirement for a fuse link, which must be able to safely interrupt the maximum system voltage when a fault occurs. The voltage rating of an industrial fuse link is usually defined in AC RMS voltages, and few industrial fuse links have an assigned DC rating.

DC faults are notoriously more difficult to clear than AC faults, the sinusoidal nature of alternating current assists with extinguishing the arcs inside the fuse during operation, this is not the case within a DC system where the voltage remains constant. Two variables should be considered in a DC system:

- 1) Fault circuit time constant (L/R)
- 2) Minimum prospective short-circuit current

It is not possible to define one DC voltage rating to cover considerable varying fault conditions and therefore specialised fuse links and specific application testing become the only option under DC conditions. Typically, the time constant of the fault conditions is $< 5\text{ms}$ limiting the complexity of design, however the short-circuit level is variable depending on the state of the battery during a fault and the minimum prospective short-circuit current level can often be very low.

Current dimensioning

The fuse link rated current is the RMS current it can continuously carry without degrading or exceeding the applicable temperature rise limits under well-defined and steady-state conditions. The well-defined conditions for industrial fuse links are stated in standard IEC 60269 for the following application conditions:

- 1) Ambient temperature: Between 10°C and 30°C (lowest temperature conditions specified at -5°C)
- 2) Current density of busbars: 1.3 A/mm²
- 3) Open air
- 4) Steady-state (no cyclic loading)
- 5) Static conditions (no vibration)

In an automotive environment however these parameters tend to differ significantly, and as such the fuse's rating needs to be reassessed for each specific application to ensure that the selected fuse link is not run beyond its current carrying capabilities; as this will lead to premature aging of the fuse and will cause it to nuisance operate.

Fuse link selection criteria

1. Basic selection
2. Temperature derating
3. Thermal connection derating
4. Cooling air correction
5. High altitude derating
6. Enclosure correction factor
7. Cyclic loading
8. Influence of overloads
9. Coordination with relays and other protection components
10. Fuse selection
11. Worked example

1. Basic selection

This part covers the basic selection criteria for only the fuse link's rated current and not the influence from overload and cyclic loading. The actual RMS steady-state load current passing through the fuse link should be lower or equal to the calculated maximum permissible load current called I_{bms} .

$$I_{bms} = I_n \times K_t \times K_e \times K_v \times K_a \times K_x$$

I_{bms} : The max permissible continuous RMS load current

I_n : Rated current of a given fuse link

K_t : Ambient temp. correction factor per Fig. 1

K_e : Thermal connection factor per Fig. 2

K_v : Cooling air correction factor per Fig. 3

K_a : High altitude derating factor

K_x : Enclosure correction factor

2. Temperature derating - K_t

Current ratings are valid for ambient temperature of $\sim 20^\circ\text{C}$

Higher ambient air temperature will impede the fuses ability to dissipate heat by convection. Typically EV fuses are placed in environments where temperatures are specified to reach a maximum of $60 - 80^\circ\text{C}$.

For ambient temperatures higher than 20°C , it is important to consider the derating factor K_t .

See example below: Ambient 60°C , $K_t = 0.8$

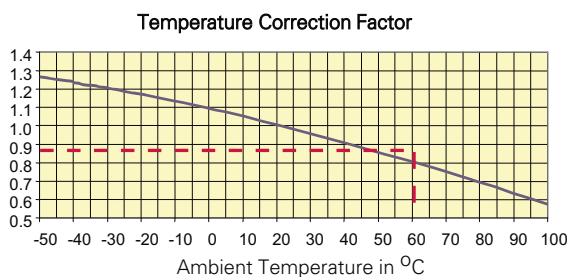

Figure 1

This curve shows the influence of the ambient temperature on the fuse link's current carrying capability.

3. Thermal connection derating - K_e

The busbar and cabling attached to the fuse link help conduct heat away from the fuse and allow it to run cooler. It is important to consider that when the cross sectional area of these conductors reduces in size, heat is not transferred as effectively.

To reduce weight and size, smaller light weight cabling is favored by vehicle manufacturers. This will however significantly differ from the conductor size used when testing the fuse under IEC conditions. As such the derating factor K_e should be observed.

=> The maximum current density of the busbars on which the fuse links are mounted should be $1.3\text{A}/\text{mm}^2$ (IEC 60269 part 4 defines 1.0 to $1.6\text{A}/\text{mm}^2$). If the busbars carry a current density more than this then the fuse link should be derated as per the graph fig 2.

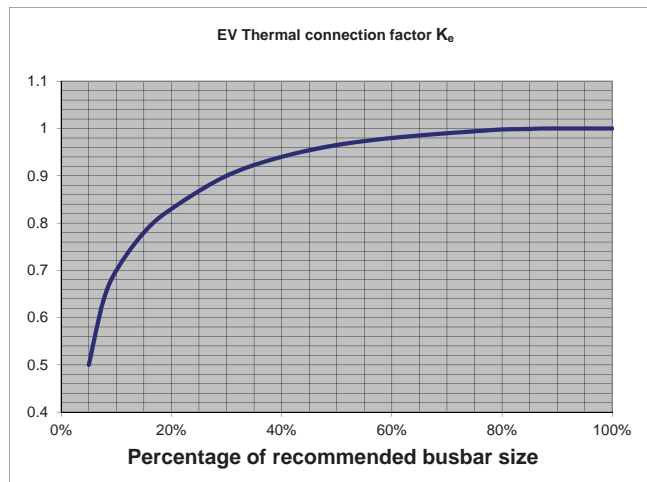

Figure 2

4. Cooling air correction - K_v

EV fuse links may be mounted in a vented enclosure, with additional cooling provided by an electric fan to help dissipate heat.

Please note that the airspeed is measured across the fuse link and not the across the fan.

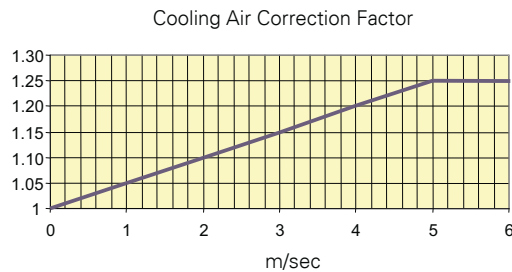

Figure 3

5. High altitudes derating - K_a

When fuses are used at high altitudes, there is a reduced cooling effect on the fuse as the density of the atmosphere reduces. Correction K_a should be applied to the fuse's continuous rating when the application is above 2000m:

$$K_a = 1 - \left(\frac{h - 2000}{100} \times \frac{0.5}{100} \right)$$

6. Enclosure correction factor K_x

High speed fuses are given their current rating in an open air environment. In automotive applications the fuse is often mounted in a small enclosure with no ventilation which will cause the fuse to run a lot hotter. We advise you apply a 0.8 enclosure factor to ensure the fuse does not run too hot.

7. Cyclic loading

Cyclic loading that leads to premature fuse link fatigue is defined as regular or irregular variations of the load current, each of a sufficient size and duration to change the temperature of the fuse link elements in such a way that the very sensitive restrictions (necks) will fatigue. In order to avoid this condition, calculations can be made to ensure there is an appropriate safety margin for the selected fuse link.

Most fuses used on electric vehicles will see these cyclic conditions, the main pack fuses connected between the drives and battery will see varying levels of current, as the power demands of the vehicle is constantly changing.

Vehicle manufacturers will usually provide numerous drive profiles that simulate typical driving conditions. These drive profiles can be used as a basis to select the correct current rating of fuse.

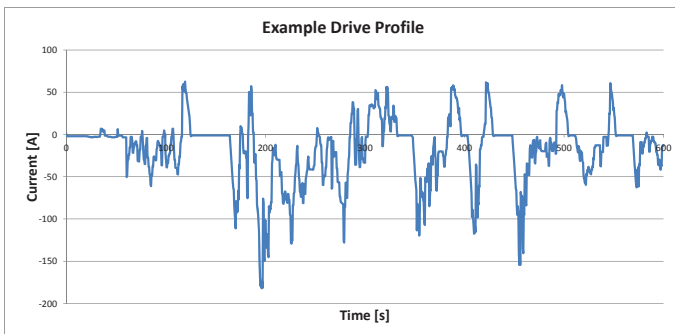

Figure 4

While using the following empirical rules will cover most cyclic loading conditions, it is impossible to set up general rules for all applications, so please contact Eaton's application engineering team for further advice: bulehighspeedtechnical@eaton.com.

- Regular or irregular variations of the load current
- Causes the temperature to fluctuate
- Heavy thermal cyclic loading leads to mechanical stress premature aging/fatigue
- Solution: Reduce ΔT of the fuse link by selecting a higher rated fuse link
- Use 'G-factor' to apply a safety margin in the fuse link selection
 - 1.6 in typical general industrial application
 - 1.3 in EV applications - irregular but not generally high overloads (average temperature of elements)
- $I_n > I_{RMS} * G$

a. Cyclic loading - G Factor

We would consider the effect of $G = 1.3$ type of heating on elements in EV cyclic loading

$$I_n \geq \frac{I_{rms} \times G}{K_t \times K_e \times K_v \times K_a \times K_x}$$

b. B Factor

Once a fuse has been selected using the above criteria, a check is required to see if the individual load pulses (each expressed in I_{pulse} , t_{pulse} coordinates) have a sufficient safety margin B in relation to I_t of the fuse's melting curve. It is the melting current of the fuse corresponding to the duration of the pulse ($t = t_{pulse}$), and B to be found per Fig.8.

$$1. I_{pulse} < I_t * B$$

This should ensure a sufficient lifetime of the fuse when subject to the given loadings.

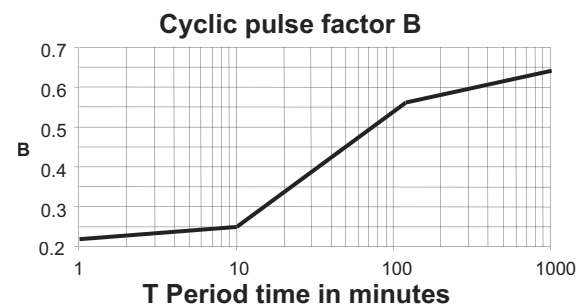

Figure 5

8. Influence of overloads

After the current rating has been selected using factors 1 to 7 it is important to check the influence of short term overloads on the fuse.

In EV applications the overload condition should not come within 50% of the current required to melt the fuse in that time. This can be reviewed on the selected fuse's time current curve.

$$I_{\max} < (50\%) \times I_t$$

Where:

I_{\max} : RMS current of the overload [A]

I_t : melting current corresponding to the time t of the overload duration, as read from the time current curve of the fuse.

a. Influence of overloads example

A **200 A** fuse link has been selected and is subjected to temporary overloads of **300 A rms for 5s**.

From the time current curve of the fuse I_t is found to be 650 A for 5 seconds.

$$I_{\max} < 50 \% \times I_t = 50 \% \times 650 = 325 \text{ A}$$

This means that the 200 A fuse selected is able to withstand the temporary overload of 300 A for 5 seconds, as the above equation is fulfilled.

9. Coordination with relays and other protection components

Unlike industrial applications, EV applications often hold specific requirements to coordinate with a relay or breaker to cover all fault conditions – low and high short circuit currents.

Typically the relay deals with the low overload currents and the fuse-link deals with high magnitude short circuits.

The fuses as part of a larger system will have to meet coordination requirements such as the selective coordination between multiple fuses in the circuit as well as between the contactor/relay. The latter, in our experience, can be rather challenging. Once the fuses have been selected as individual components based on the current carrying capability, they more often than not have to coordinate with the contactor/relay during a fault scenario. The challenge is that the fuses will have to be quick enough to operate well before the contactor would either overheat or exceed its breaking condition, but the fuses also have to be slow enough to survive currents due to the rigorous driving profiles.

For further assistance please consult Eaton Application engineering department: bulehighspeedtechnical@eaton.com

10. Fuse selection

a. Factors affecting fuse link selection

- DC voltage capability
- Current de-rating
- Physical size and type



BS 88



North American



Ferrule



Square body

b. Common end tag options (square body on

DIN 43653

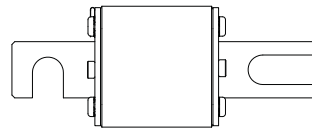

US or BS88 Blade style

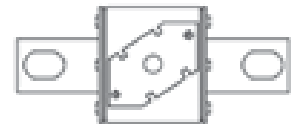

French

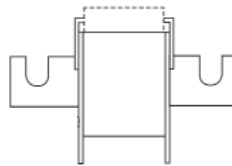

Flush end

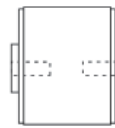

c. Internal design modifications

Care must be taken when selecting product for electric vehicle applications. Industrial designs are often modified to accommodate for the harsh environments experienced in EV applications. There are many factors to consider including thermal shock, vibration, high relative humidity and high ambient temperatures.

Mechanical fuse link packages can be used as a base design, where internal modifications are made. The finalised design is then tested in accordance to the specific OEM requirements.

11. Worked example

A high speed fuse is required to protect an EV battery system. A number of typical drive profiles are given for the application, all of which are cyclic, the rms current over each cycle is calculated and the most onerous profile is determined to be **300 A_{rms}**. The starting ambient air temperature is **50 °C** and the fuse is mounted in a **small enclosure** with no ventilation. It is decided that the cabling used to electrical connect the fuse will be **130mm²**. It is also specified that the vehicle needs to function up to **2500m** above sea level.

First of all we calculate the minimum required current rating as per the below equation:

$$I_n \geq \frac{I_{rms} \times G}{K_t \times K_e \times K_v \times K_a \times K_x}$$

$$I_{rms} = 300 \text{ A}$$

$$K_t = 0.85 \text{ Figure 1 for } 50 \text{ °C ambient temperature}$$

$$K_e = 0.97, \text{ Figure 2 for } 56\% \times \text{IEC}$$

$$100\% \text{ IEC Cable size} = \frac{\text{RMS Current}}{1.3 \text{ A / mm}^2} = \frac{300}{1.3} = 230.8 \text{ mm}^2$$

The cabling being used is only **130mm²**, which is 56% of the IEC cable size.

$$K_v = 1, \text{ the fuse isn't cooled by a fan}$$

$$K_a = 0.975$$

2500m above sea level gives:

$$K_a = 1 - \left(\frac{2500 - 2000}{100} \times \frac{0.5}{100} \right) = 0.975$$

$$K_x = 0.8, \text{ the fuse mounted in a } \text{small enclosure} \text{ with no ventilation}$$

G = 1.3, the drive profile is not a steady state load current, it is cyclic

$$I_n \geq \frac{300 \times 1.3}{0.85 \times 0.97 \times 1 \times 0.975 \times 0.8}$$

$$I_n \geq 606 \text{ A}$$

The minimum required current rating is 606 A, so the next available IEC current rating is chosen: 630 A.

Secondly we need to check the short term overloads to ensure they do not damage the fuse selected and cause it to prematurely age, one overload condition identified as particularly onerous in the drive cycle is 1000 A for 3 seconds. We need to plot this on the selected fuse's time current curve to make sure the below equation is satisfied:

$$I_{max} < (50\%) \times I_t$$

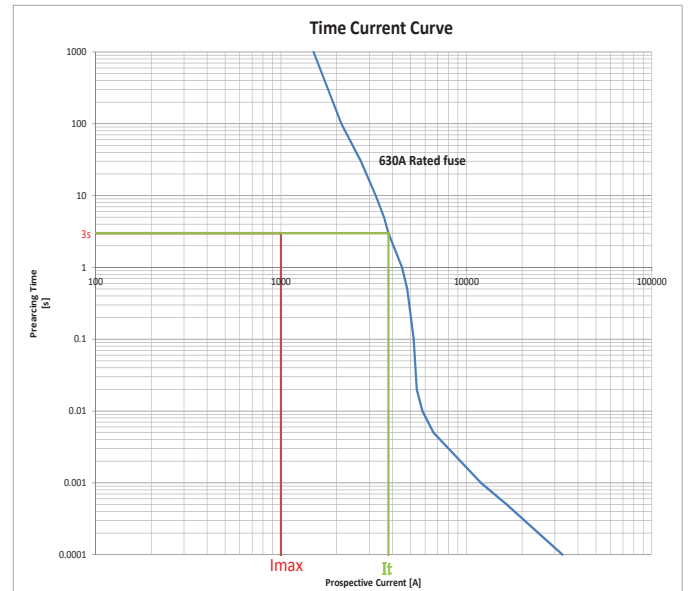

Figure 6

$$I_{max} = 1000 \text{ A}$$

$$I_t = 3800 \text{ A @ } 3\text{s}$$

I_{max} is only 26% of I_t . So the overload of 1000 A for 3s is acceptable as it does not come within 50% of the current required to melt the fuse in that time.

Automotive standards and qualification

- No global standards for Electric Vehicles
 - AECQ200
 - JASO D622 - Japan
 - SAE J2781
 - ISO 8820-1
 - ISO 8820-8
- No standards cover fuse links > 500 V d.c.
- Solutions are fully catered to accommodate each OEM requirements
- In-house testing capability within Eaton
 - DC Capability
 - Shock and vibration
 - Cyclic loading

Early awareness of OEM test spec. is essential for fuse link selection.

Contact details

Customer Satisfaction team

Eaton's Customer Satisfaction team is available to answer questions regarding Bussmann series products.

Calls can be made between:

Monday - Thursday 7.30 a.m. - 5.30 p.m. GMT

Friday 7.30 a.m. - 5.00 p.m. GMT

The Customer Satisfaction team can be reached via:

Phone: 00 44 (0) 1509 882 600

Fax: 00 44 (0) 1509 882 786

Email: bulesales@eaton.com

www.my.eaton.com

Tailored just for you. Powerful online tools and resources get you the up-to-date information you need to work smarter, make informed decisions and streamline your transactions with Eaton.

Get started today at www.my.eaton.com by clicking 'Request User ID and Password'.

- Easy to Navigate
- Simple to Use
- Real-Time Data.

Online resources

Visit www.eaton.com/bussmannseries for the following resources:

- Product cross reference
- Product profiles
- Online catalogues for the latest United States and European catalogues.

Application engineering

Application Engineering assistance is available to all customers. The Application Engineering team is staffed by university-qualified electrical engineers who are available with technical and application support.

Calls can be made between:

Monday - Thursday 8.30 a.m. - 4.30 p.m. GMT

Friday 8.30 a.m. - 4.00 p.m. GMT

Application Engineering can be reached via:

Phone: 00 44 (0) 1509 882 699

Fax: 00 44 (0) 1509 882 794

General technical enquiries:

buletechnical@eaton.com

Enquiries related to EV and other high speed fuses:

bulehighspeedtechnical@eaton.com

At Eaton, we're energized by the challenge of powering a world that demands more. With over 100 years experience in electrical power management, we have the expertise to see beyond today. From groundbreaking products to turnkey design and engineering services, critical industries around the globe count on Eaton.

We power businesses with reliable, efficient and safe electrical power management solutions. Combined with our personal service, support and bold thinking, we are answering tomorrow's needs today. Follow the charge with Eaton. Visit eaton.com/electrical.

Contact your local Eaton office

Eaton
Melton Road
Burton-on-the-Wolds
LE12 5TH
Leicestershire
United Kingdom
bulesales@eaton.com
www.eaton.com/bussmannseries

Changes to the products, to the information contained in this document, and to prices are reserved; so are errors and omissions. Only order confirmations and technical documentation by Eaton is binding. Photos and pictures also do not warrant a specific layout or functionality. Their use in whatever form is subject to prior approval by Eaton. The same applies to Trademarks (especially Eaton, Moeller, and Cutler-Hammer). The Terms and Conditions of Eaton apply, as referenced on Eaton Internet pages and Eaton order confirmations.

Eaton
EMEA Headquarters
Route de la Longeraie 7
1110 Morges, Switzerland
Eaton.eu

© 2016 Eaton
All Rights Reserved
Printed in the United Kingdom
Publication No. BR132016EN
June 2016

Eaton is a registered trademark.

All other trademarks are property of their respective owners.

Follow us on social media to get the latest product and support information.

