



EATON

Powering Business Worldwide



Eaton has more than 100 years of proven technical innovation to help make your operation more productive while protecting your equipment.

Energy storage is a necessity as the world is becoming more electrified, leading to changes in system architectures and their overcurrent protection needs. Eaton is continually developing designs to meet these ever changing requirements. Battery storage systems scale from residential to commercial and utility scale applications.

The experience and expertise of Eaton in protecting DC applications and semiconductor devices is proving invaluable in the development of fusible circuit protection for battery storage systems.

Table of contents

Battery storage systems in an electrical grid network	4 - 5
Battery storage systems introduction	6
IEC 60269-7 standard	6
Battery storage systems applications	6 - 7
Battery storage fuse links selection criteria	8 - 12
Voltage dimensioning	8
Current dimensioning	8 - 11
Worked example	12
Custom solutions and simulation capabilities	13
Battery storage fuse links, fuse bases and microswitches overview	14
BSF-NH Battery storage fuse links	15 - 21
SD-D-PV NH Bases for battery storage fuse links	22 - 23
BSF-3L Battery storage fuse links	24 - 26
SD3L-S-PV XL bases for battery storage fuse links	27

Where battery storage systems fit in the electrical grid network



Different types of battery storage systems



Medium scale battery storage containers

- Schools
- Offices
- Shopping Centres
- Farming

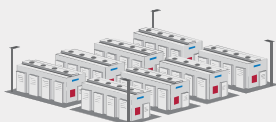

Utility large scale battery storage containers

- Solar Farm
- Wind Farm
- Industrial Customers

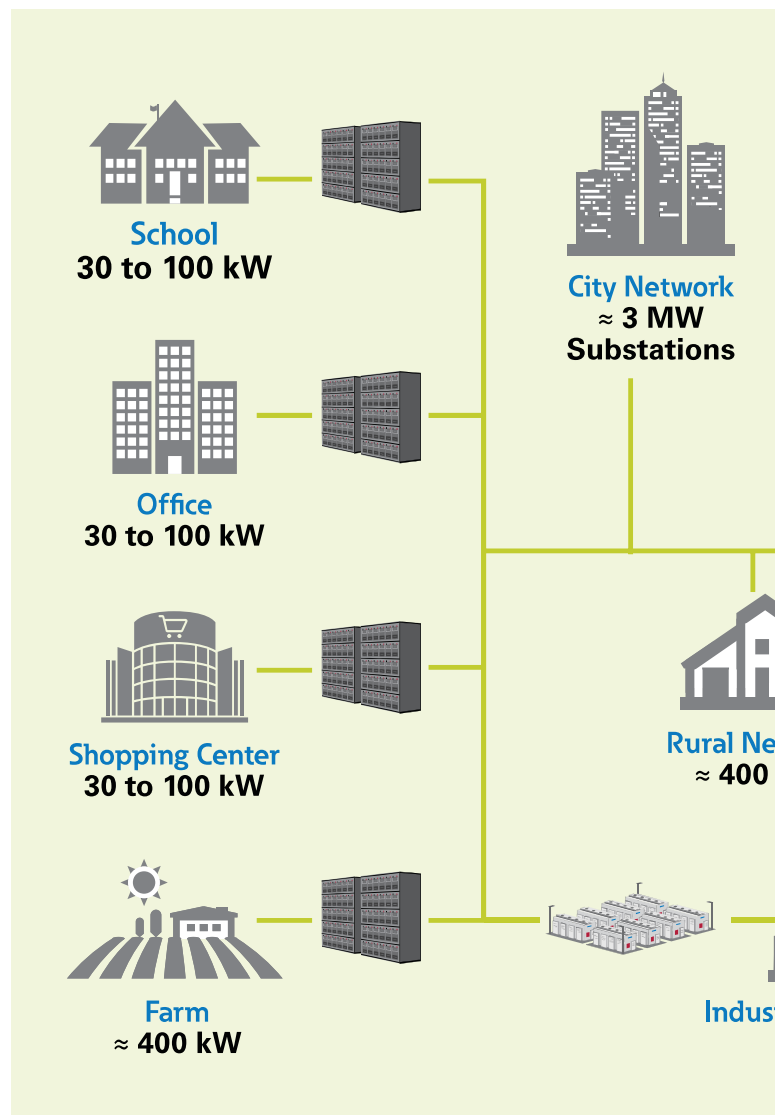

- Distribution Grid -

Battery storage system in an electrical grid network



Powering Business Worldwide

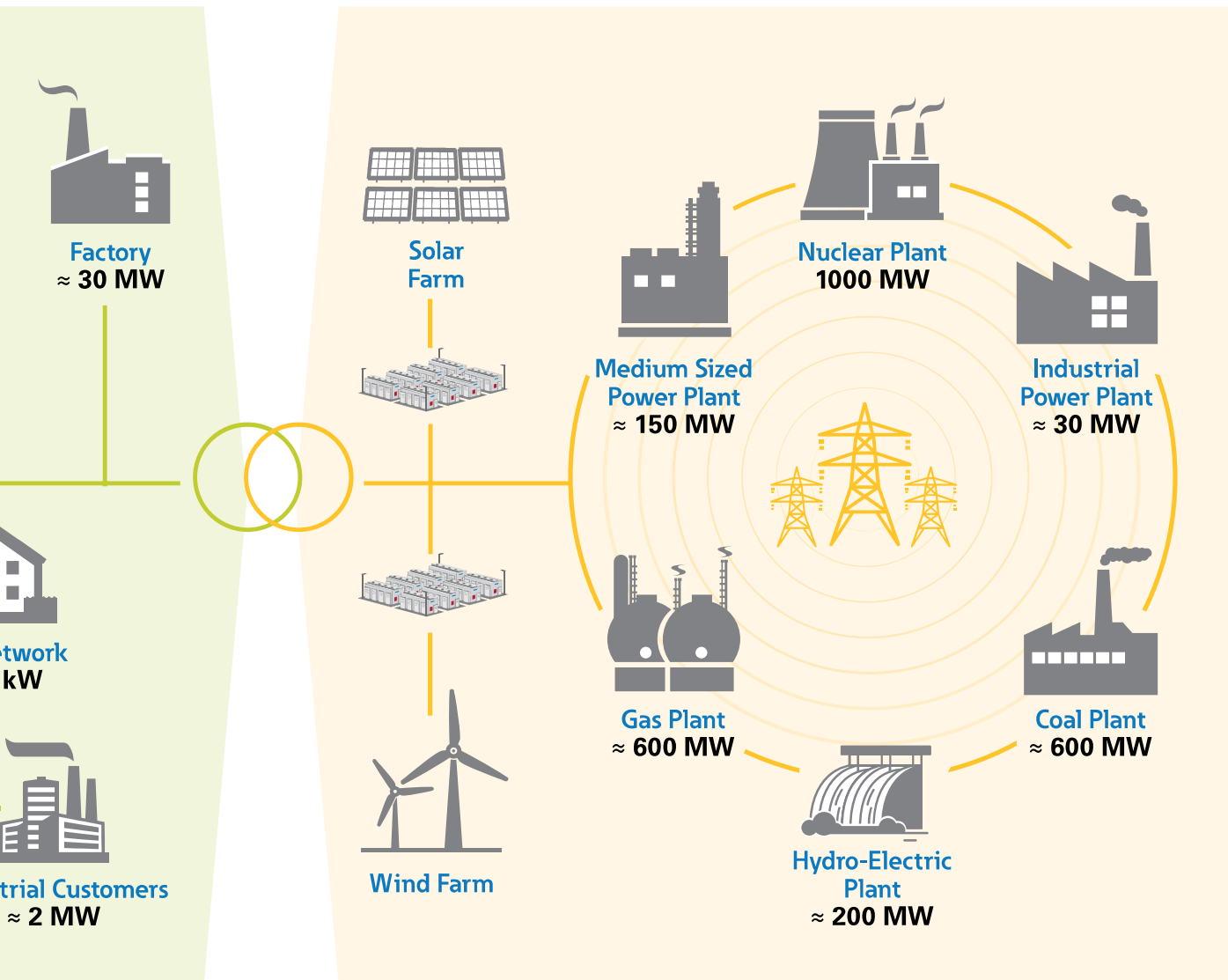
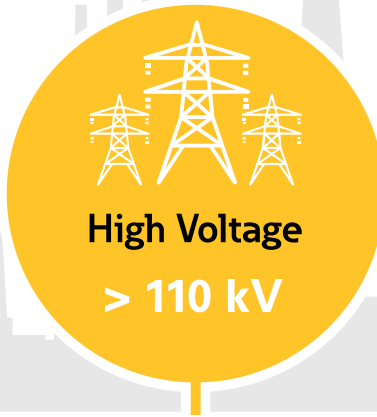

- Transmission Grid -

Introduction and draft IEC 60269-7 Battery storage fuse links standard

Introduction

Power demand is forever increasing. Traditional energy generation has been supported, in the last decade, by the growth of renewable energy technology such as solar, wind and tidal. The need to store the energy generated, by both traditional and renewable methods, is becoming necessary to make sure power is continually provided where and when required.

Battery storage systems provide a number of advantages of being modular, easily deployable in proximity to power generation applications and even retro fitted to existing systems.

Draft IEC 60269-7 Battery storage fuse links standard standard

The protection requirements within battery Storage systems are quite different when compared to typical grid connected AC systems. In battery systems the protective devices are required to operate in DC systems which may have high faults currents and a number of lower over current situations. For this reason, Eaton has conducted extensive research and development of its Eaton's Bussmann series fuse links that are specifically designed and tested to safely protect battery storage systems with high DC voltages and low fault currents.

The International Electrotechnical Commission (IEC) has recognised the protection of Battery Storage systems is different to standard electrical installations. This is reflected in the proposed standard IEC 60269-7 which will define specific characteristics that a fuse link is required to meet for protecting Battery Storage Systems, with the inclusion utilisation classes gBat and aBat. The two classes reflect the configurations where full range or partial range protection is required. The proposed standard also reflects the battery storage systems may have high fault currents. Eaton's range of Bussmann series battery storage fuse links has been specifically designed to meet this proposed standard.

Contact our team of Field Application team for further information bulehighspeedtechnical@eaton.com

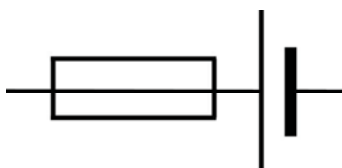

To identify fuse links to the proposed standard the combination of the symbols for fuse-link and a single cell are used to indicate a fuse-link is suitable for protecting batteries, particularly in storage systems, see Figure 1.

Figure 1

Battery storage system applications

Battery storage systems have become one of the most common form of electrical energy storage that converts electrical energy from the grid, solar and wind farms into a stored form for later use in residential homes, commercial buildings industrial sites,

Eaton's Bussmann series has a vast array of fuse links able to support your applications. Contact our team of Field Application team for further information bulehighspeedtechnical@eaton.com

Residential battery storage applications

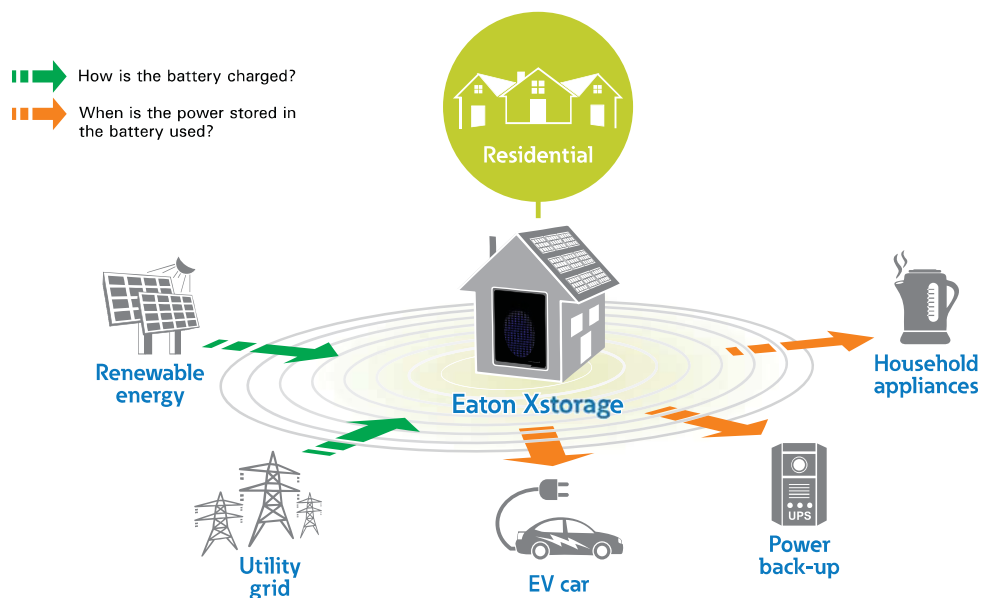

Battery storage system applications

Commercial scale battery storage applications

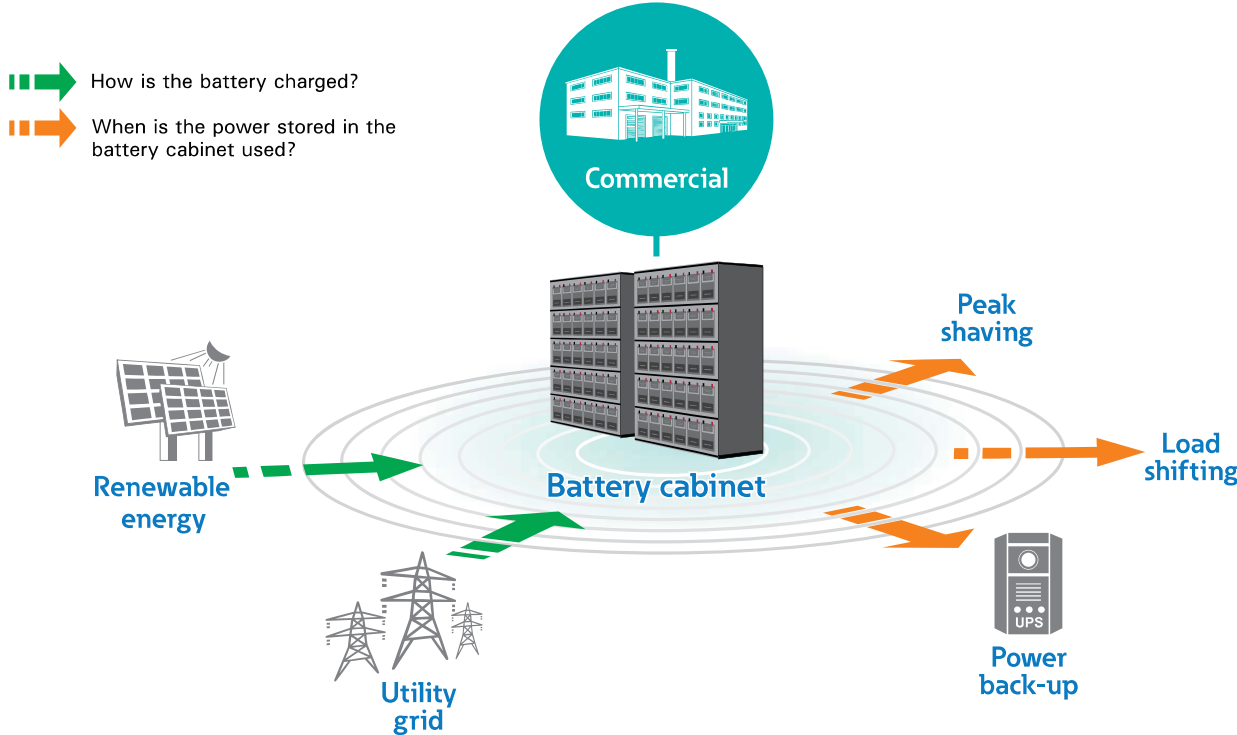

Utility scale battery storage applications

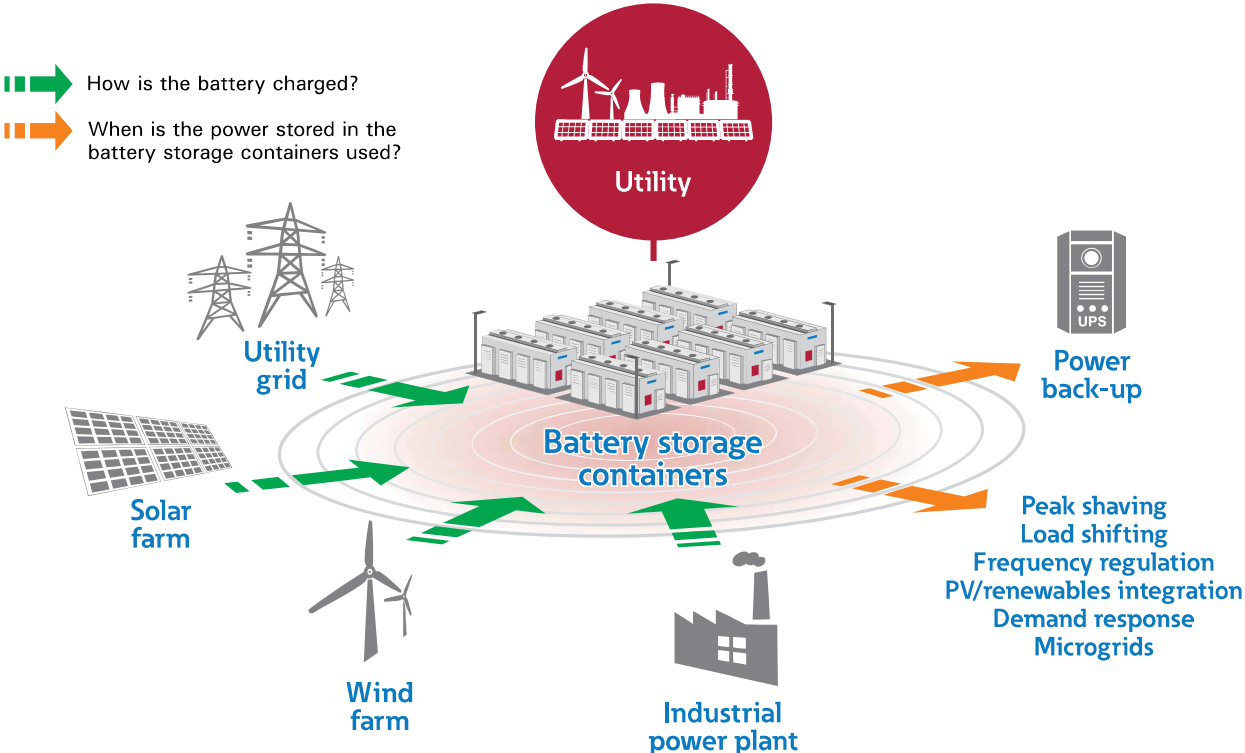

Battery storage fuse links selection criteria

Voltage dimensioning and current dimensioning

How to select an array fuse for battery storage applications

Various type of batteries are used in storage systems: Lead acid, lithium-ion, AGM, Nicad. These batteries have varying characteristics based on chemistry, construction and manufacturer. The Battery Management System (BMS) will ensure the battery health and that the battery cannot be over charged or over discharged. The BMS together with a suitable overcurrent protection device such as a fuse link will provide protection to the battery.

The selection of an appropriate fuse link should consider the circuit time constant and short-circuit current, as they will vary depending on the battery state of charge.

You will find below a basic guide in selecting the appropriate array fuse link. For support on selecting a module fuse please contact our Field Applications Team bulehighspeedtechnical@eaton.com

To select the correct fuse link for battery storage systems the criteria below need to be considered

- **1.1 Voltage dimensioning**

- **1.2 Current dimensioning**

- 1.2.1 Basic selection
- 1.2.2 Temperature derating K_t
- 1.2.3 Thermal connection de-rating K_e
- 1.2.4 Cooling air correction K_v
- 1.2.5 High altitude derating K_a
- 1.2.6 Overload
- 1.2.7 Cyclic loading
- 1.2.8 Coordination with contactors and circuit breakers

- **1.3 Worked example**

1.1 Voltage dimensioning

The voltage rating of a battery fuse link indicates the maximum DC it has been designed to operate. In order to properly protect the battery system, the fuse link voltage rating must be at least equal to the maximum open circuit voltage of the battery.

One fuse link on its own should be able to operate at the maximum open circuit voltage of the battery, if two or more fuse links are in series in a short-circuit path, each fuse link should be rated above the maximum open circuit voltage of the battery.

The fuse links should be selected to ensure the circuit time constant is less than that the fuse links are tested to.

1.2 Current dimensioning

The fuse link rated current is the RMS current that it can continuously carry without degrading or exceeding the applicable temperature rise limits of the fuse-link under well-defined and steady-state conditions.

1.2.1 Basic selection

This section covers the basic selection criteria only for the fuse links' rated current and not the influence from overload and cyclic loading. To avoid premature operation, the fuse link current rating when modified for external influences on the rating should be greater than the calculated RMS current of the application.

$$\text{Fuse current rating selected } (I_n) \geq \frac{I_b}{K_t \times K_e \times K_v \times K_a \times K_b}$$

- I_n : Rated current of a selected fuse
- I_b : The continuous RMS load current through the fuse in actual application
- K_t : Ambient temperature correction factor
- K_e : Thermal connection factor
- K_v : Air cooling correction factor
- K_a : Correction factor for high altitude
- K_b : Fuse link case correction: 1.0 for ceramic, 0.8 for non-ceramic

1.2.2 Temperature derating K_t

The fuse link current rating is confirmed at an ambient test temperature of 20°C. Higher ambient air temperature will influence the fuse links ability to dissipate heat by convection. For ambient temperature above 20°C, a de-rating factor K_t should be applied to de-rate the fuse link current rating.

Fig1 . Battery energy storage fuse links - factor for derating with increased temperature

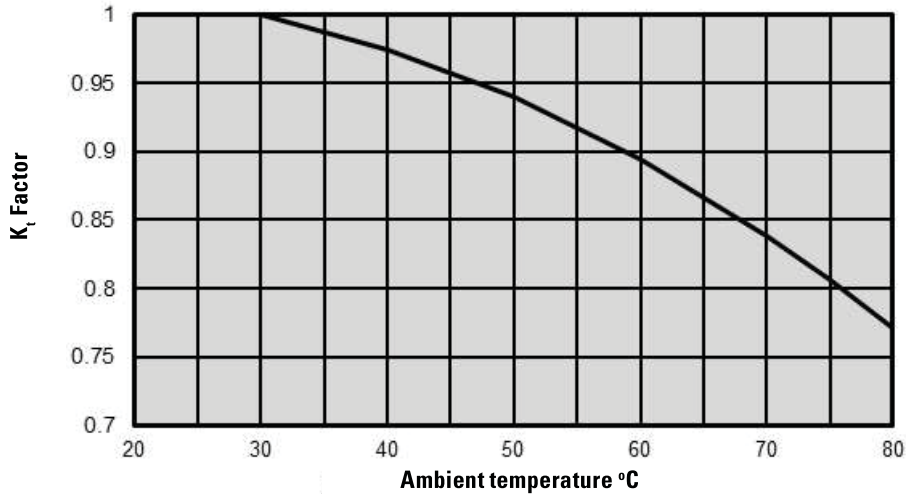

1.2.3 Thermal connection derating K_e

The busbar and cabling attached to the fuse link help to conduct heat generated by the fuse link away from the fuse link itself. Eaton recommends the current density of the busbar, on which the fuse links are mounted, should be 1.3 A/mm². If the busbar carries a current density more or less than 1.3, then the fuse needs to be de-rated as per illustration below.

For example; a 200 A rated fuse link is to be mounted onto a busbar with cross sectional area of 120 mm². The recommended busbar size for a 200 A fuse is 154 mm² (200/1.3 A/mm²), but the actual busbar size is only 78% (120 mm² /150 mm²) of the recommended size; so the fuse link should be de-rated according to the thermal de-rating factor shown in the graph below (black lines), in this case $K_e=0.98$.

Fig 2. Thermal correction factor

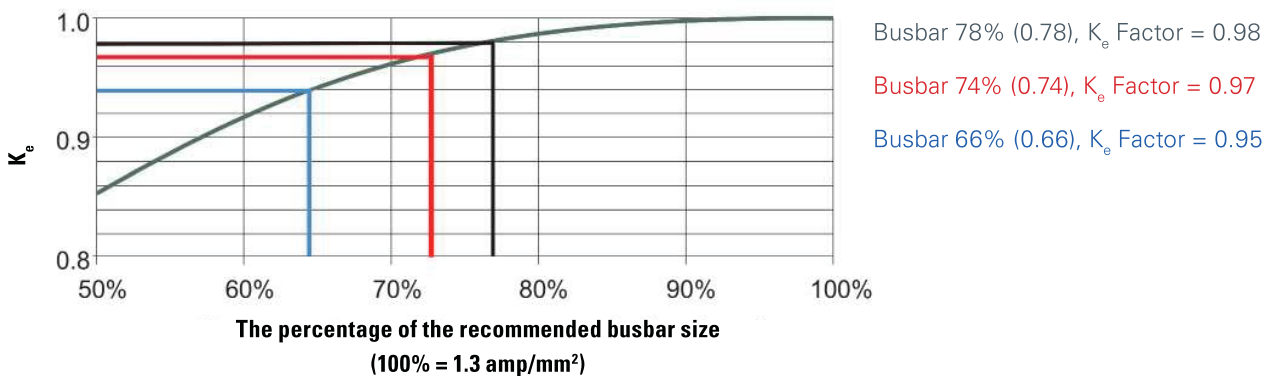

For full range fuse links, the fuse links are rated based on the connections being standard cross section PVC cable sizes .

Battery storage fuse links selection criteria

Current dimensioning

1.2.4 Cooling air correction K_v

When there is additional forced air cooling available it helps to dissipate the heat from the system, including from the fuse links. A factor K_v can be applied to the fuse link current carrying capability based on the cooling air speed measured across the fuse link.

Fig 3. Cooling air correction factor

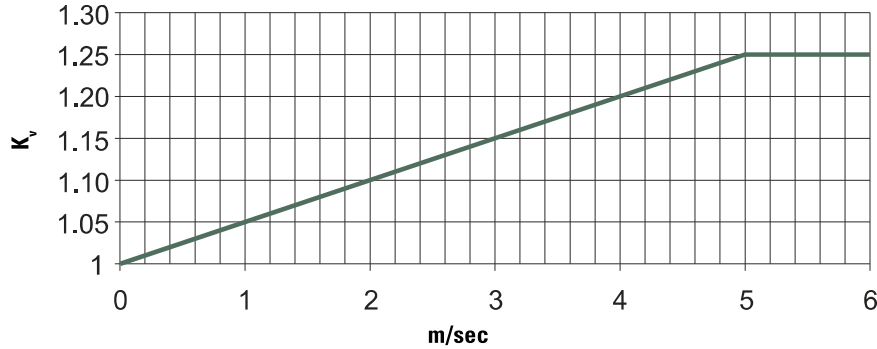

1.2.5 High altitude derating K_a

When fuse links are installed at high altitude, the air density is lower than at ground level, so the natural cooling effect of air is reduced. Correction factor K_a should be applied to the fuse link's continuous rating when the application is above 2000 meters.

$$K_a = 1 - \left(\frac{h - 2000}{100} \times \frac{0.5}{100} \right)$$

h = altitude in meters

1.2.6 Overload

In many systems a fuse link will be subjected to currents above the stated rated current for short durations as part of the normal system operation, e.g. motor starting conditions. These may be referred to as expected overloads. By knowing the details listed below it is possible to check if the selected fuse link can or cannot withstand the overload.

- Overload current
- Overload duration
- How often does the overload happen?

1.2.7 Cyclic loading

Whilst standard tests confirm a given fuse link capabilities with specific overcurrent and duration, situations that differ from the standard should be considered as cyclic loading and the fuse link selection should be based on the criteria below.

In many circuits with cyclic currents, the RMS current will be relatively low compared to the peak currents in the cycle, if the time when the current is high is short compared to when the current is low, see example current profile below.

In such cases, selection of the fuse link based on RMS current alone will result in a fuse link that will suffer premature operation. In order to select an appropriate fuse link current rating the equation to select the correct rated fuse link (see section 1.2.1 page 8) will require modification to compensate for the cyclic nature.

$$\text{Fuse current rating selected } (I_n) \geq \frac{I_b \times G}{K_t \times K_e \times K_v \times K_a \times K_b}$$

G: Correction factor for cyclic applications, typically G may be as high as 2.0.
For BES applications we would usually use a G correction factor of 1.5.

Please contact our Field Application Engineering team for further information on cyclic loading bulehighspeedtechnical@eaton.com

While using the empirical rules will cover many cyclic loading conditions, it is impossible to set up general rules for all applications, please consult Eaton Field Application Engineering Team at bulehighspeedtechnical@eaton.com for guidance on any specific cyclic loading profile.

Example charging-discharging current profile

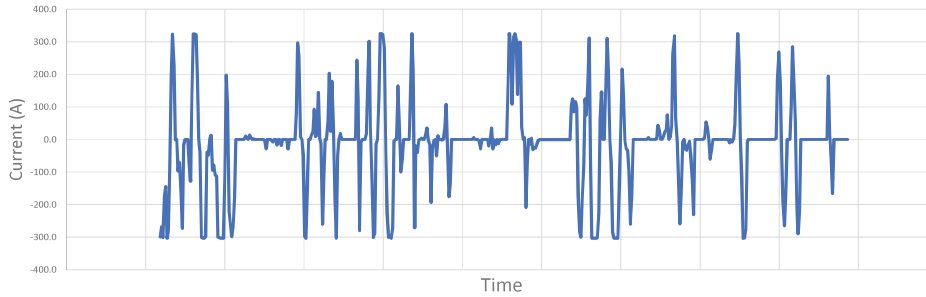

1.2.8 Coordination with contactors

For support with selecting the correct fuse links to coordinate with contactors our Field Applications Engineering Team will require the details and data sheet for your desired contactor to ensure the specified fuse link will provide adequate electrical circuit protection, please email bulehighspeedtechnical@eaton.com if you require assistance

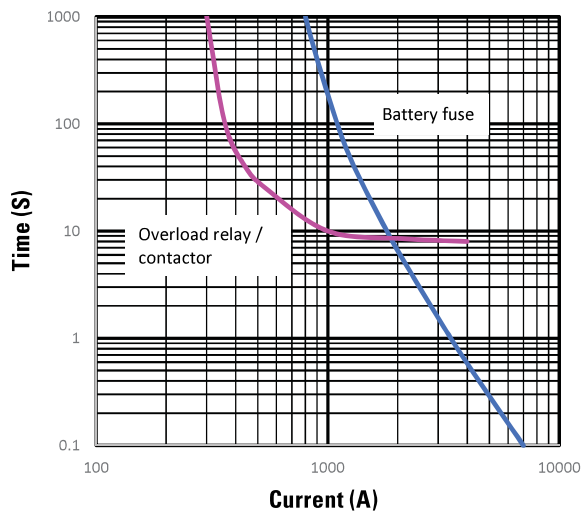

Battery storage fuse links selection criteria

Worked example

1.3 Worked example

A fuse link is required to protect a battery storage application in Europe. You'll find below the calculation to find out the current rating of the selected fuse link.

Battery storage system specifications

- RMS current of the cycle: 180 A
- Maximum system voltage: 800 V d.c.
- Maximum ambient temperature around the fuse: 40°C
- Fuse link is mounted on a busbar with a cross sectional area of 180 mm²
- Forced air cooling 4 ms/s

Calculation

I_b	= 180 A	Given from the system and cycling loading details
G	= 1.5	Typical battery charging/discharge cycle
K_t	= 0.9	See fig 1. For 40°C ambient temperature
K_e	= 0.94	See fig 2 and below IEC dimensions
K_v	= 1.2	See fig 3 for 4m/s forced air cooling
K_a	= 1	Worked example assumed below 2000 meters
K_b	= 0.8	The selected fuse has glass fiber case

$$\text{Fuse current rating selected } (I_n) \geq \frac{I_b \times G}{K_t \times K_e \times K_v \times K_a \times K_b}$$

Before the fuse current rating is defined the K_e factor is unknown. You will find below the initial fuse current rating **without** the K_e factor.

$$\text{Fuse current rating selected } (I_n) \geq \frac{I_b \times G}{K_t \times K_v \times K_a \times K_b} = \frac{180 \times 1.5}{0.9 \times 1.2 \times 1 \times 0.8} = 312.5 \text{ A}$$

A 315 A fuse link is considered as it is the nearest current rating to 312.5 A available in our Eaton's Bussmann series battery storage fuse links range.

The battery system specification states that the fuse link will be mounted on a 180 mm² busbar. However, for a 315 A fuse link, the IEC recommended busbar size is 242mm² (315A/1.3A/mm²). This actual busbar size 180mm² is only 74% of the recommended size (180/242=74%). By reading on the thermal connection de-rating (red lines) fig.2 page 9, the K_e factor is 0.97 for 74%.

Now the fuse current rating has been calculated at 315 A, the fuse link current rating can be checked against the K_e factor of 0.97.

$$(I_n) \geq \frac{312.5 \text{ A}}{0.97} = 322 \text{ A}$$

Whilst a 315 A is initially configured, based on the busbar derating K_e factor = 0.97, the suggested fuse rating needs to be greater than 322 A.
A 355 A fuse link is considered as it is the nearest current rating to 322 A available in our Eaton's Bussmann series battery storage fuse links range.

A 273 mm² busbar is recommended for a 355 A fuse link (355 A/ 1.3 A/mm²). When dividing the busbar dimensions: 180/273 = 0.66, so when reading the thermal connection de-rating (blue lines) fig.2 page 9, the K_e factor is 0.95 for 66%.

The final fuse current rating with the revised K_e factor is 329 A

$$(I_n) \geq \frac{312.5 \text{ A}}{0.95} = 329 \text{ A}$$

For use in Europe, a NH style Battery storage fuse link is the recommended style. The nearest fuse rating available in our range is a 355 A, the catalogue number is [BSF-355-NH310-B](#).

Custom solutions and simulation capabilities

Custom solutions

Our Field Applications Engineering team is here to support you to select a suitable fuse link from Eaton's Bussmann series fuse links portfolio. Eaton can customise fuse fixings: bolted, bladed or flush end to meet the application's requirements.

Simulation capabilities

Battery storage applications experience cyclic loading currents during charging and discharging activities. Current cyclic causes the temperature fluctuation of fuse elements as shown in the figure below

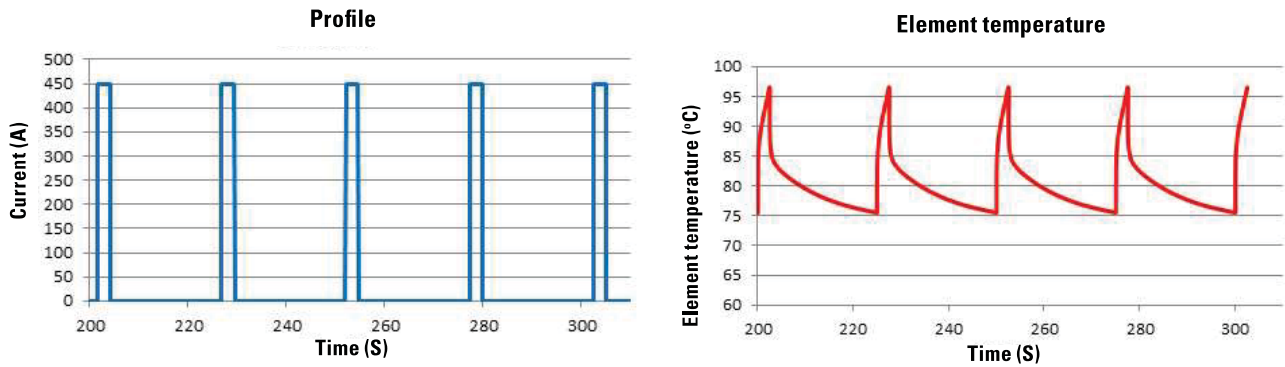

Repeated high current pulses lead to metal fatigue from grain boundary disruption followed by crack propagation and failure. The thermal-mechanical stress accumulation will promote abnormal fuse melting.

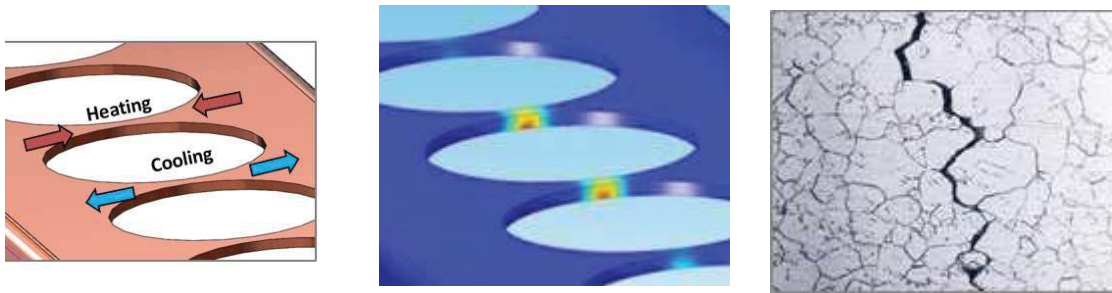

Hence lifetime prediction of the fuse link has become a popular topic for battery storage protection. Eaton has developed the Life Prediction Model to estimate the number of current cycles that fuse link could withstand based on customers' specific cycling loading profile. We also analyse the temperature of the fuse element and connection tags to give accurate prediction.

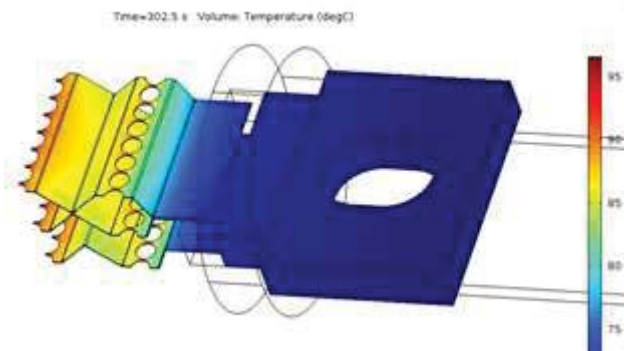

Repeated high current pulses lead to metal fatigue from grain boundary disruption followed by crack propagation and failure. The thermal-mechanical stress accumulation will promote abnormal fuse melting.

Our new simulation tool will help us to predict the lifetime of the battery storage applications:

- Repetitive current cycling load profile
- Ambient temperature around the fuse
- Busbar material and size
- Air cooling speed
- Maximum altitude
- If the fuse link is installed in sealed enclosures

For simulation request, please contact Eaton's Field Application Engineering team on bulehighspeedtechnical@eaton.com

Battery storage fuse links, fuse bases and microswitches overview

Battery storage fuse links offering specifications

Body type	Body size	Fuse type	Catalogue number	Rated current (A)	Rated voltage (V d.c.)	Standard IEC 60269-7	Data sheet number
NH	NH1	NH Bladed	BSF-(amps)G-NH110	63, 80, 100, 125, 160, 200	1000	✓	135001
		NH Bolted	BSF-(amps)G-NH110-B	63, 80, 100, 125, 160, 200	1000	✓	135001
	NH2	NH Bladed	BSF-(amps)G-NH210	160, 200, 250	1000	✓	135001
		NH Bolted	BSF-(amps)G-NH210-B	160, 200, 250	1000	✓	135001
	NH3	NH Bladed	BSF-(amps)G-NH310	315, 355, 400	1000	✓	135001
		NH Bolted	BSF-(amps)G-NH310-B	315, 355, 400	1000	✓	135001
XL	3L	XL Bladed	BSF-(amps)G-3XL15	250, 315, 355, 400, 450, 500	1500	✓	135002
		XL Bolted	BSF-(amps)G-3XL15-B	250, 315, 355, 400, 450, 500	1500	✓	135002



Fuse bases and microswitches

Fuse size	Fuse type	Fuse bases		Microswitches
		Catalogue number	Data sheet	Catalogue number
NH1	Bladed	SD1-D-PV	720149	170H0236 and 170H0238
	Bolted	N/A	N/A	N/A
NH2	Bladed	SD2-D-PV	720149	170H0236 and 170H0238
	Bolted	N/A	N/A	N/A
NH3	Bladed	SD3-D-PV	720149	170H0236 and 170H0238
	Bolted	N/A	N/A	N/A
XL	Bladed	SD3L-S-PV (up to 400 A)	10685	170H0236 and 170H0238
	Bolted	N/A	N/A	170H0069



NH battery storage fuse links, 63 to 400 A, 1000 V d.c., BSF-NH

Description

Eaton's Bussmann series NH battery storage fuse links are specifically designed to protect and isolate battery array combiners and disconnects. These fuse links are capable of interrupting low overcurrents associated with faulted battery storage systems.

Fuse size

NH1, NH2 and NH3

Catalogue number

Knife blade fuse links: BSF-(amps)G-NH(Body size)10

Bolted fuse links: BSF-(amps)G-NH(body size)10-B



Bolted fuse links

Bladed fuse links

Technical data

- Rated voltage: 1000 V d.c.
- Rated current: 63 to 400 A
- Breaking capacity: 100 kA
- Class of operation: gBat proposed for full range fuse links for protection of battery storage systems
- Time constant: 4.5 ms at 100 kA

Standards/Approvals

- IEC 60269-7
- RoHS and REACH compliant

Packaging

MOQ: 3

Packaging 100% recyclable

Technical data

Catalogue number with knife blade	Catalogue number with bolted blade	Fuse body size	Rated current (Amps)	Rated voltage (V d.c.)	Pre-arcing I _{2t}	Total I _{2t} @ 1000 V d.c.	Power loss at 0.7 x I _n (W)	Power loss at I _n (W)
BSF-063G-NH110	BSF-063G-NH110-B	1	63	1000	470	4300	5	12
BSF-080G-NH110	BSF-080G-NH110-B	1	80	1000	640	5760	6	15.5
BSF-100G-NH110	BSF-100G-NH110-B	1	100	1000	1300	11,700	7	16.5
BSF-125G-NH110	BSF-125G-NH110-B	1	125	1000	2600	23,400	7	17.5
BSF-160G-NH110	BSF-160G-NH110-B	1	160	1000	5200	46,800	11	27.5
BSF-160G-NH210	BSF-160G-NH210-B	2	160	1000	4600	37,000	11	28
BSF-200G-NH210	BSF-200G-NH210-B	2	200	1000	9500	76,000	13	32
BSF-250G-NH210	BSF-250G-NH210-B	2	250	1000	17,000	136,000	15	38
BSF-315G-NH310	BSF-315G-NH310-B	3	315	1000	32,000	260,000	18	44
BSF-355G-NH310	BSF-355G-NH310-B	3	355	1000	44,500	370,000	18	46
BSF-400G-NH310	BSF-400G-NH310-B	3	400	1000	67,500	550,000	21	52

Microswitches for NH knife blade fuse links

Catalogue number	Fuse type	Fuse body size	Microswitches	Terminal size	Rated Voltage	Rated current
BSF-(amps)G-NH	Knife blade	1 to 3	170H0236	6.3 x 0.8 mm	250 V a.c.	5 A
			170H0238	2.8 X 0.5 mm	250 V a.c.	5 A

NH Bases for NH knife blade fuse links

Catalogue number with knife blade	Fuse body size	NH Bases
BSF-(amps)G-NH110	1	SD1-D-PV
BSF-(amps)G-NH210	2	SD2-D-PV
BSF-(amps)G-NH310	3	SD3-D-PV

Data sheet: 135001

NH battery storage fuse links, BSF-NH

Dimensions

Dimensions - NH1 Bladed fuse links

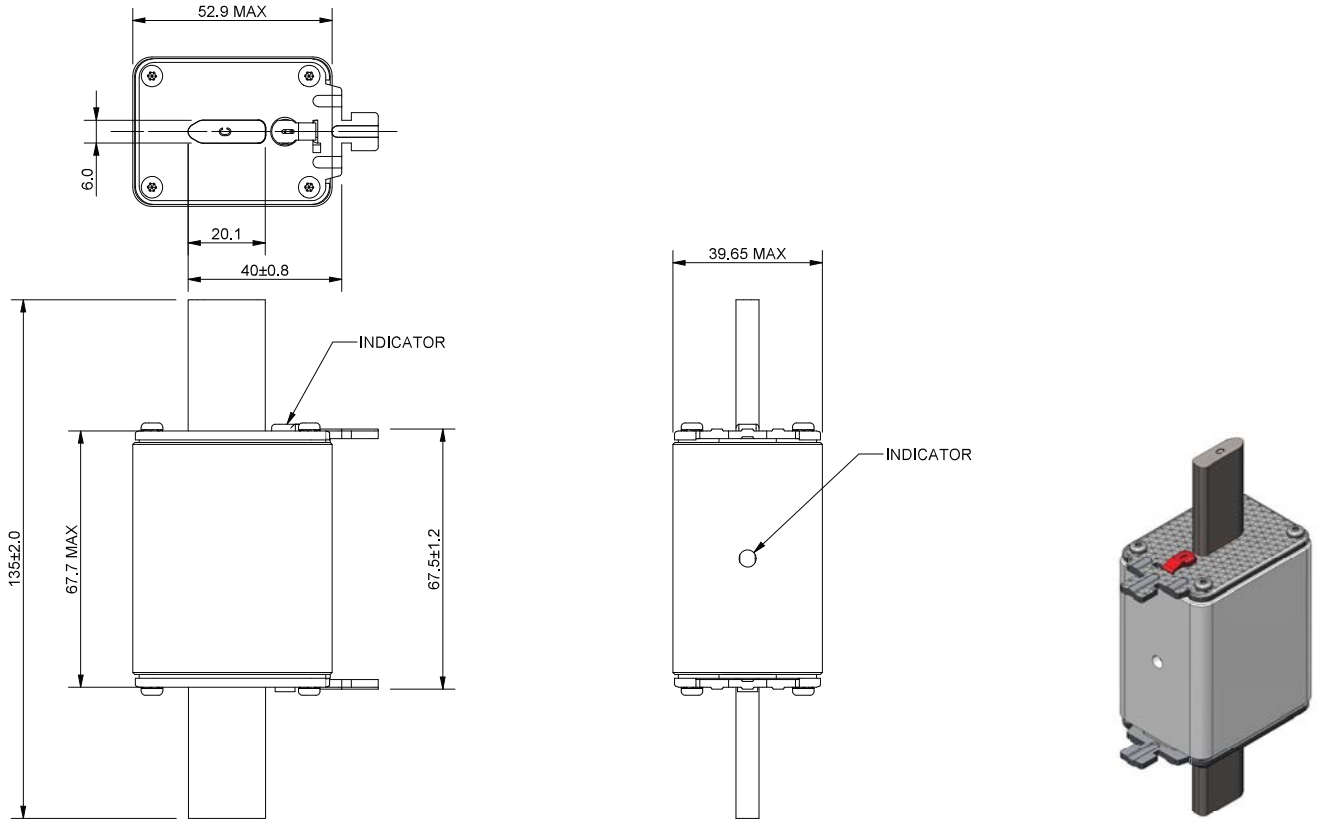

Dimensions mm - NH2 Bladed fuse links

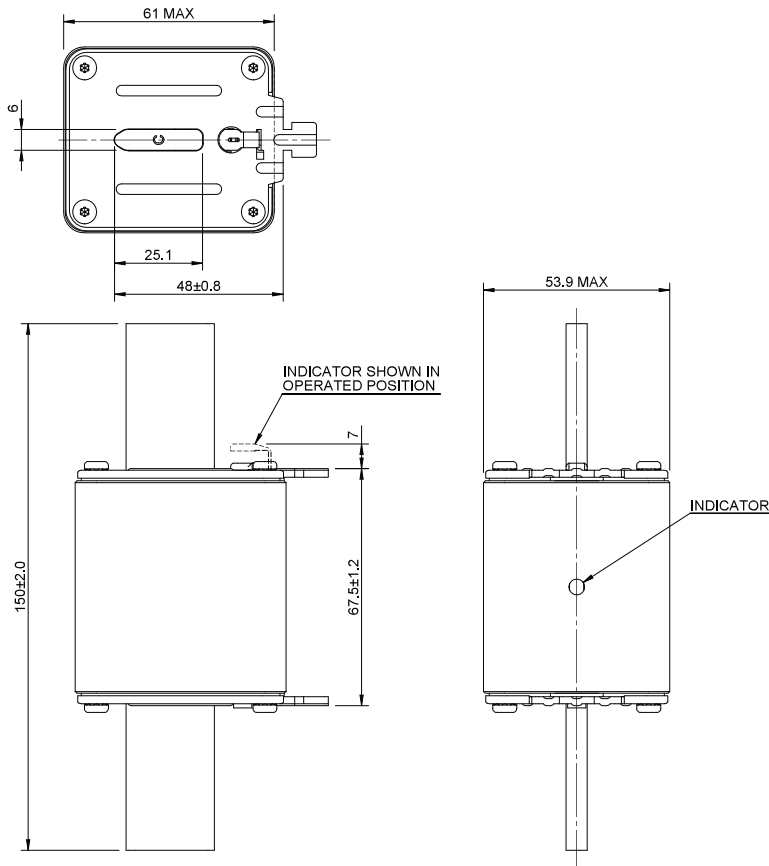

Dimensions mm - NH3 Bladed fuse links

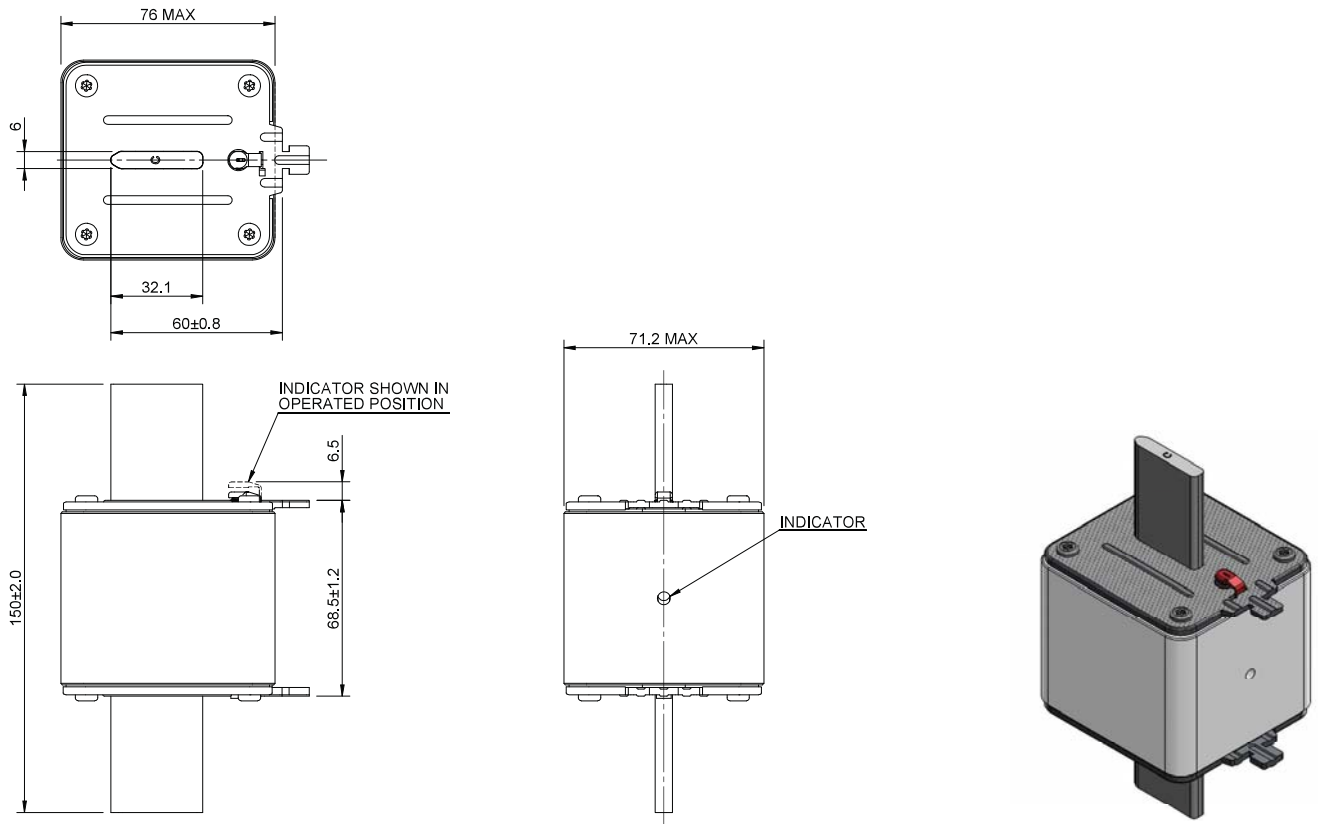

Dimensions mm - NH1 Bolted fuse links

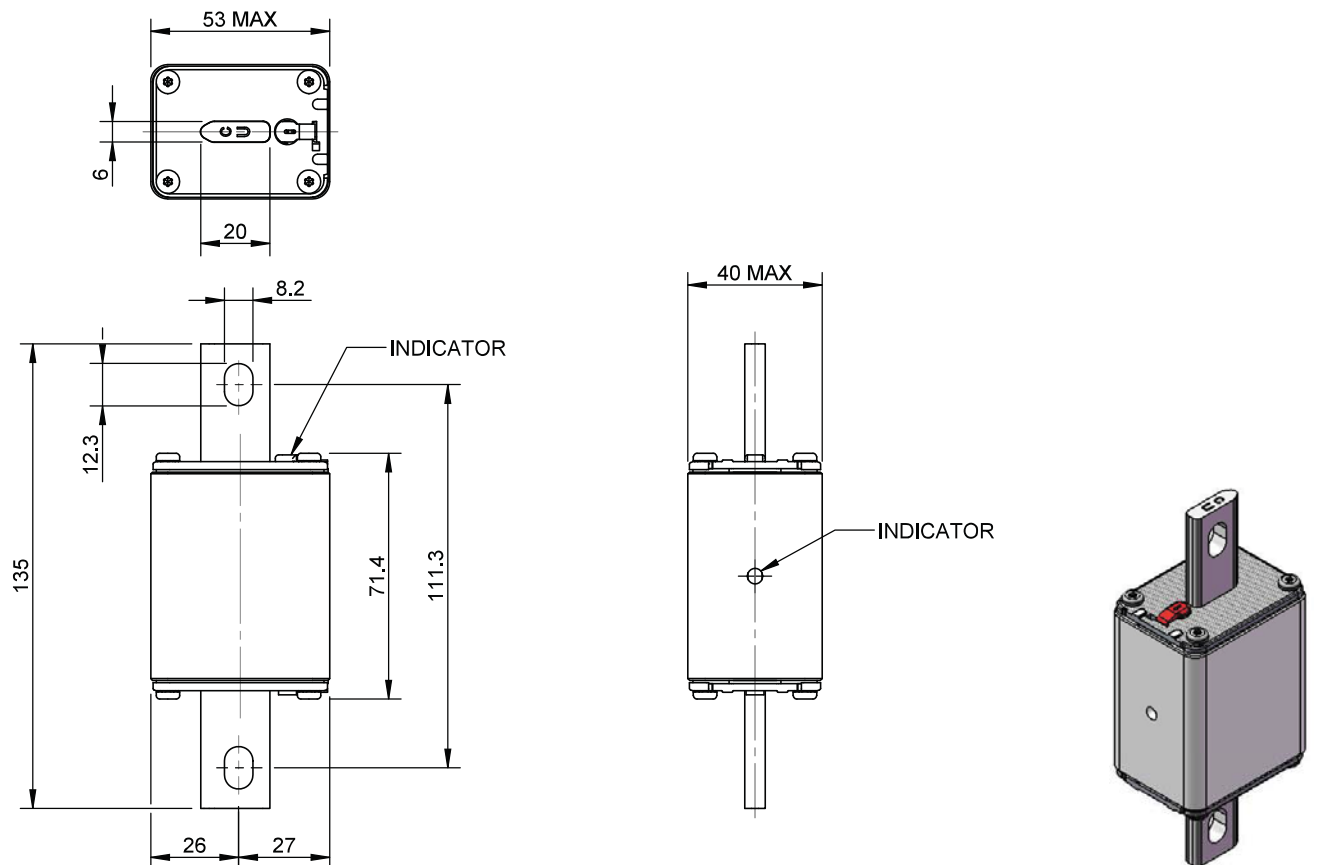

NH battery storage fuse links, BSF-NH

Dimensions

Dimensions mm - NH2 Bolted fuse links

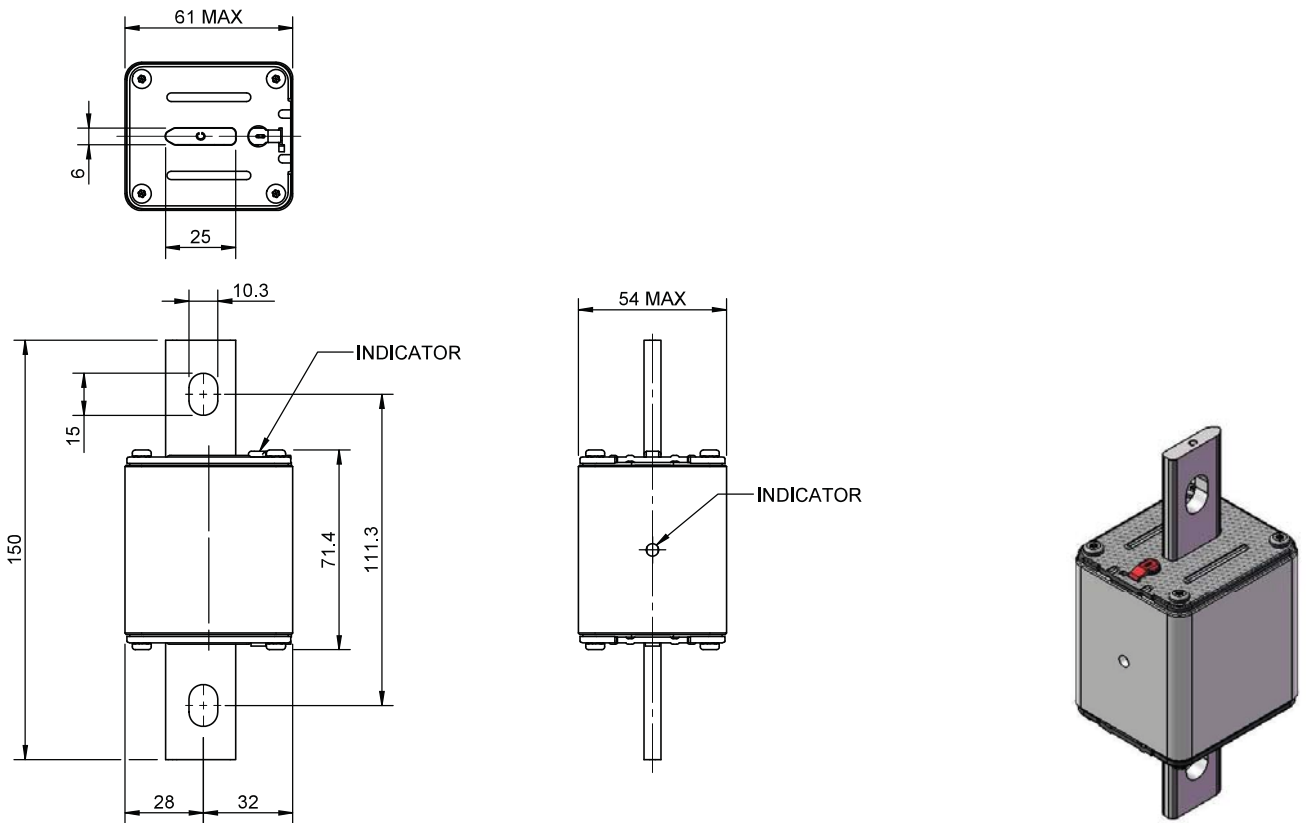

Dimensions mm - NH3 Bolted fuse links

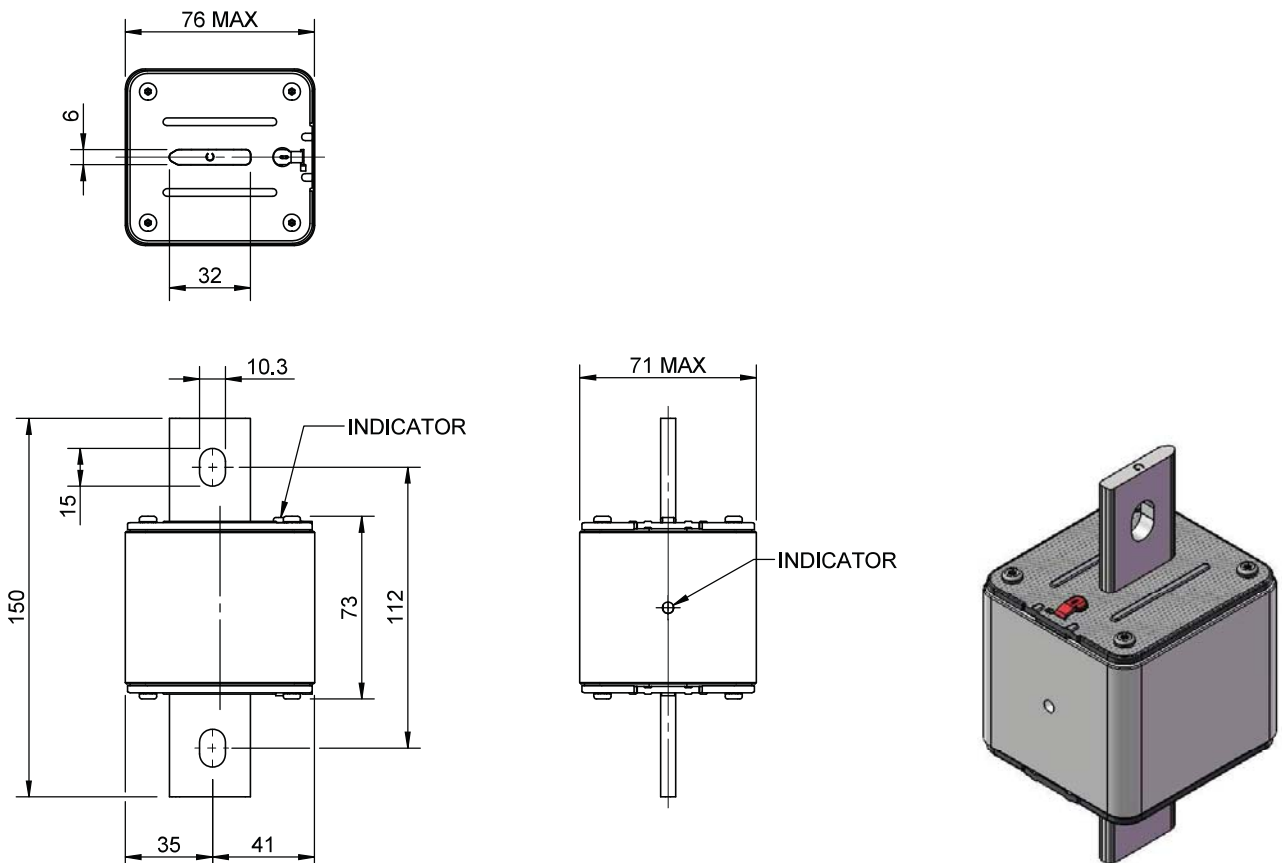

Time-current curve - NH1 fuse links

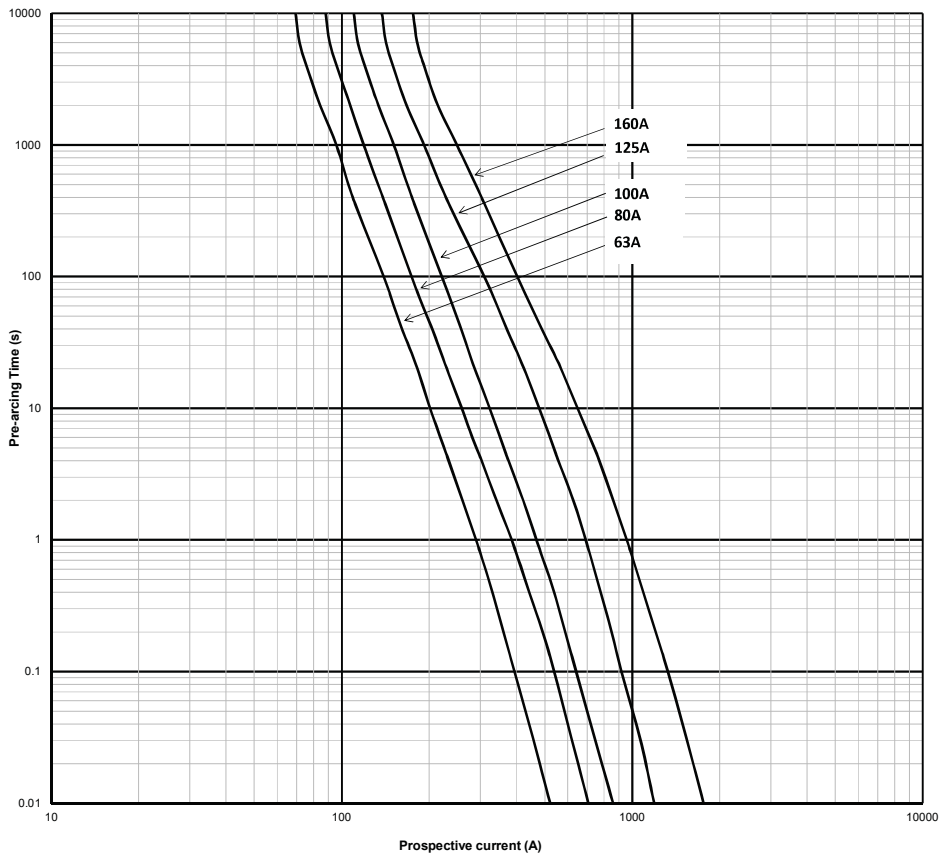

Time-current curve - NH2 fuse links

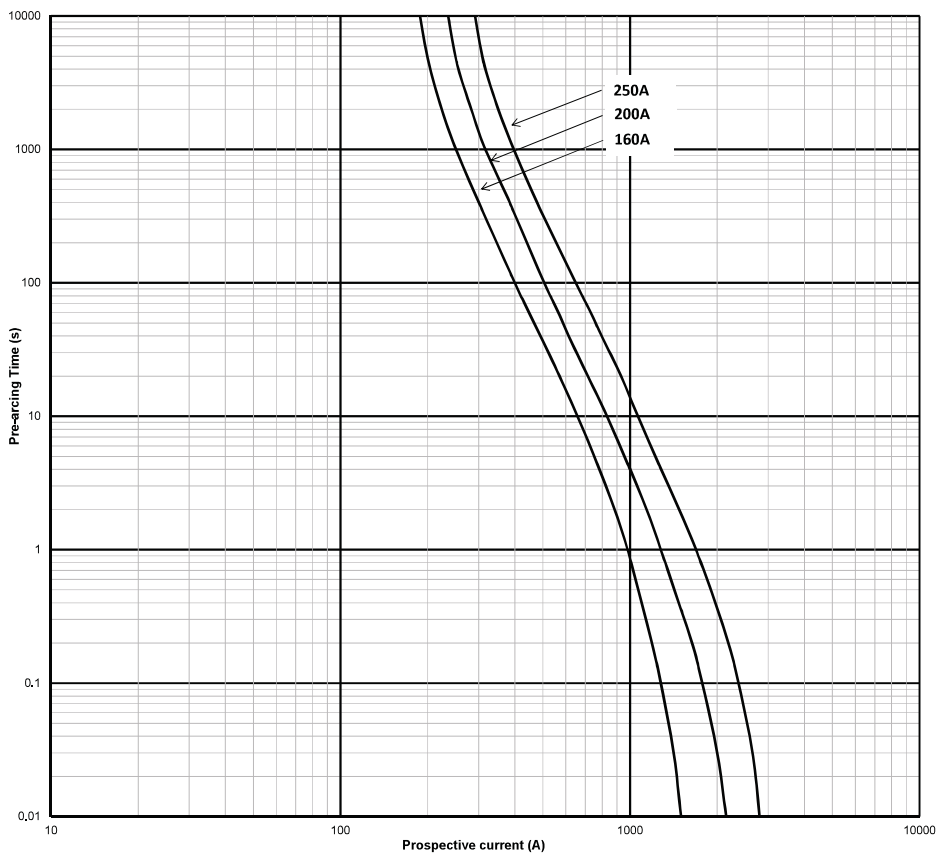

NH battery storage fuse links, BSF-NH

Time-current curve and temperature derating curve

Time-current curve - NH3 fuse links

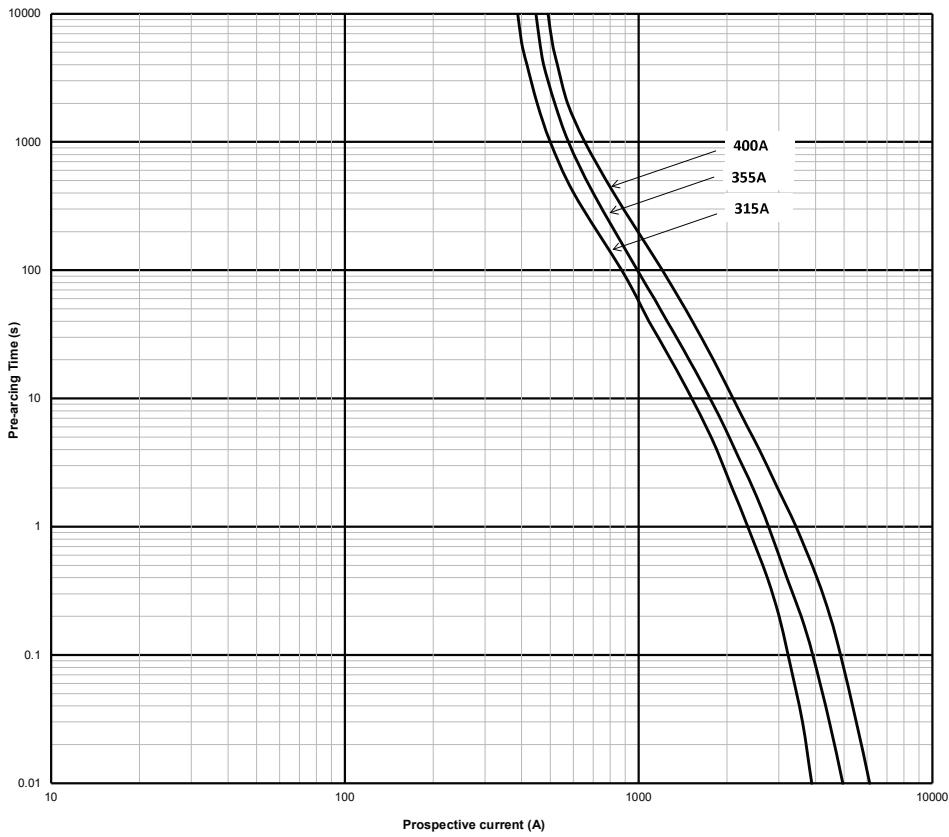

Temperature derating curve

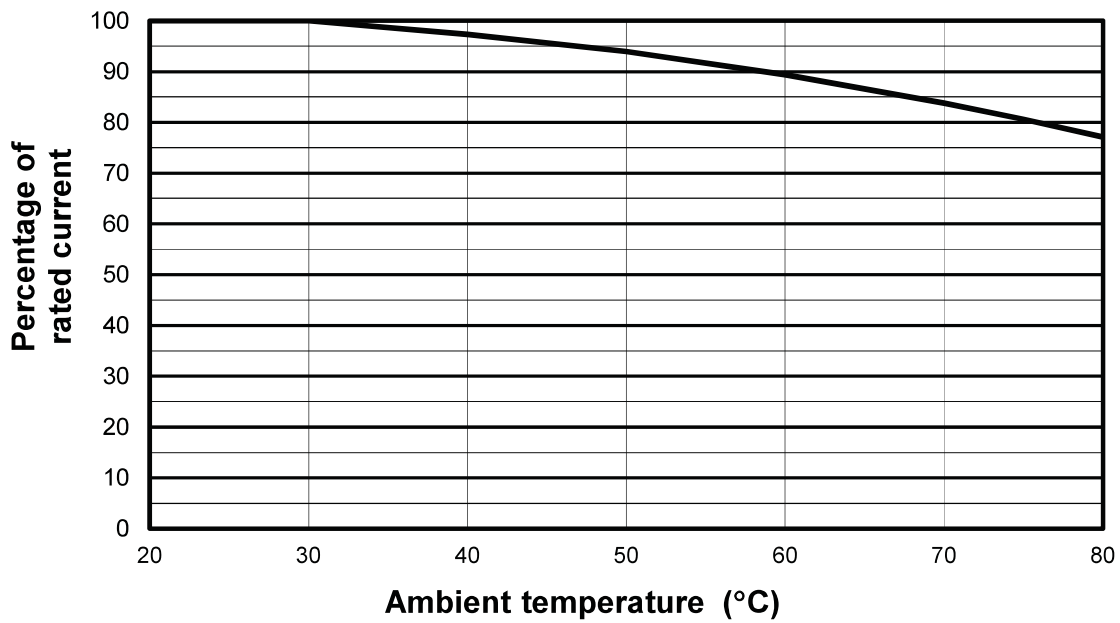

(The ambient temperature is that local to the fuse link)

Peak let-through curve

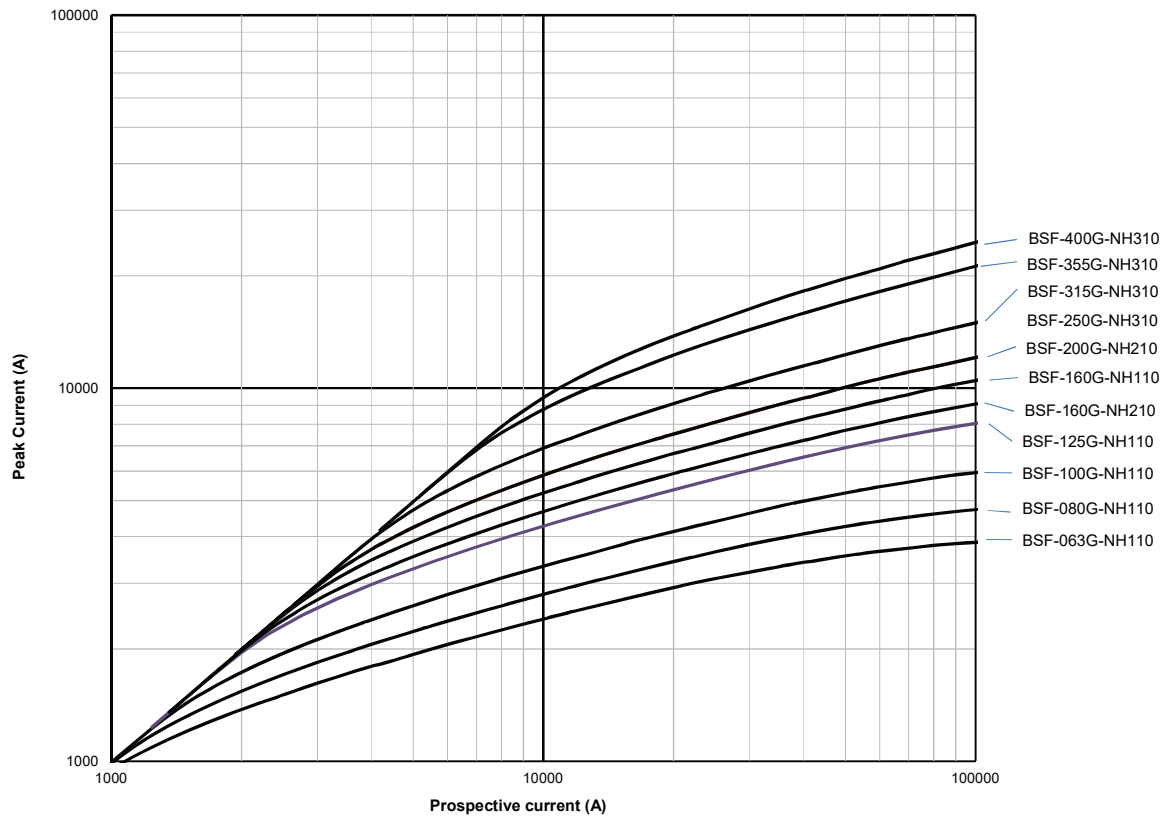

NH Bases, SD-D-PV

Technical data

NH Bases, SD-D-PV

Catalogue number

- SD1-D-PV
- SD2-D-PV
- SD3-D-PV



Technical data

- Rated voltage:
 - 1500 V d.c. (IEC)
 - 1000 V d.c. (UL)
- Rated current:
 - 250 A (SD1)
 - 400 A (SD2)
 - 630 A (SD3)
- Withstand: 50 kA
- Power acceptance
 - SD1 - 32W
 - SD2 - 45W
 - SD3 - 60W

- Protection level:

IEC - IP20 with shroud kit installed and shielding of any exposed terminal lugs

UL - Installation of shroud kit decreases the likelihood of incidental terminal contact. To ensure compliance to IP20 specifications per UL the installer must make additional provisions.

- Temperature range

Operating - IEC Standards -20°C to 70°C

- UL-20°C to 90°C Max*

Storage - IEC and UL: -40°C to 90°C

* Dependant upon rating of customer supplied lugs

- Derating factors for maximum current

Ambient	Derating factor
35°C	1.00
40°C	0.95
50°C	0.85

- Terminal/Lug mounting torque: 32N•m (283.2 Lb-In)

- Mounting

- 35 mm DIN-Rail
- Panel

- Flammability rating: UL 94V0

- Materials

- Base: Glass filled PBT
- Contacts: Silver plated copper
- Hardware: Clear zinc-plated steel

Standards/Approvals

- IEC 60269-1
- UL Listed (UL file E348242)
- CSA file 47235

Packaging: MOQ: 3

Data sheet: 720149

Accessories

Fuse extraction handle

NH fuse link body size	Current (Amps)	Catalogue Numbers	Pack Quantity
NH1-3	250- 630	FEH	1

Shroud kits

Fuse Base Series	Fuse size	Current (Amps)	Catalogue Numbers	Description
SD1	NH1	250	SD12-SK	Kit includes 2 shrouds and 1 fuse cover
SD2	NH2	400	SD12-SK	
SD3	NH3	630	SD3-SK	

Phase Barrier Kit

NH fuse link body size	Current (Amps)	Catalogue Numbers	Pack Quantity	Description
NH1	250	SD12-PB	1	2-Phase barriers and 2 ganging links
NH2	400	SD12-PB	1	
NH3	630	SD3-PB	1	



Phase barrier



Ganging link

Microswitch

Catalogue Numbers	Pack Quantity	Rated
170H0236	12	2 A 250 V a.c.
170H0238	12	2 A 250 V a.c.

1-pole changeover microswitch suitable for the following NH Battery storage bladed fuse links:

Neutral links

NH fuse link body size	Current (Amps)	Catalogue Numbers	Pack Quantity
NH1	250	SDL-1	3
NH2	400	SDL-2	3
NH3	630	SDL-3	3

Dimensions - mm 1-pole, Sizes 1, 2 and 3

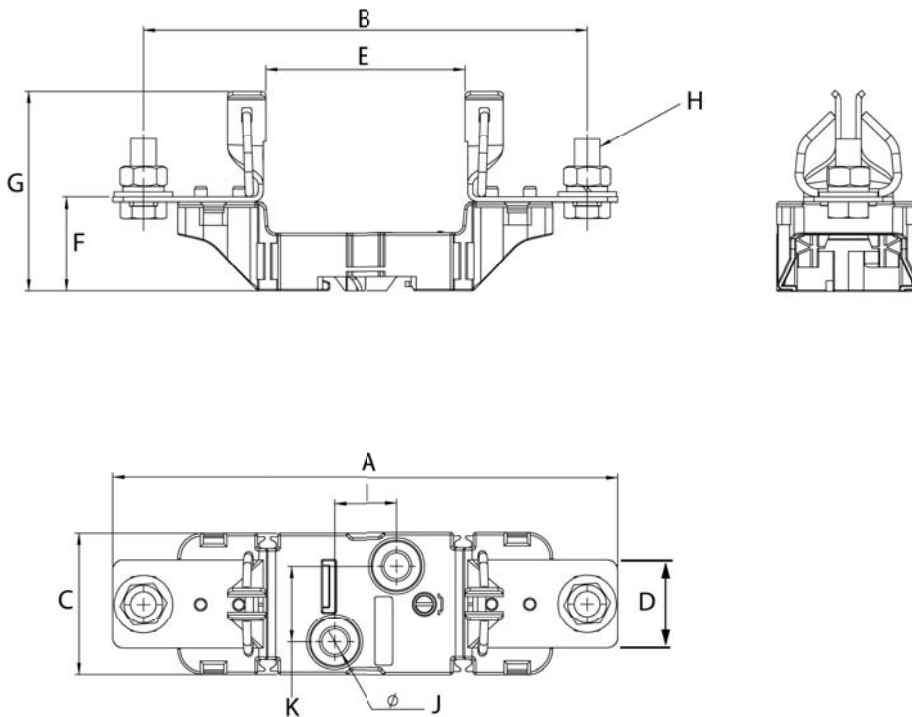

Catalogue numbers	NH Fuse link body size	A	B	C	D	E	F	G	H	I	J	K
SD1	NH1	199	175	56	35	79	37	78	M10x25	25	10	30
SD2	NH2	224	199	56	35	79	37.5	86	M10x25	25	10	30
SD3	NH3	239	209	56	36	82	37.5	88	M12x30	25	10	30

Dimensions - mm With phase barriers 1-pole sizes 1, 2 and 3

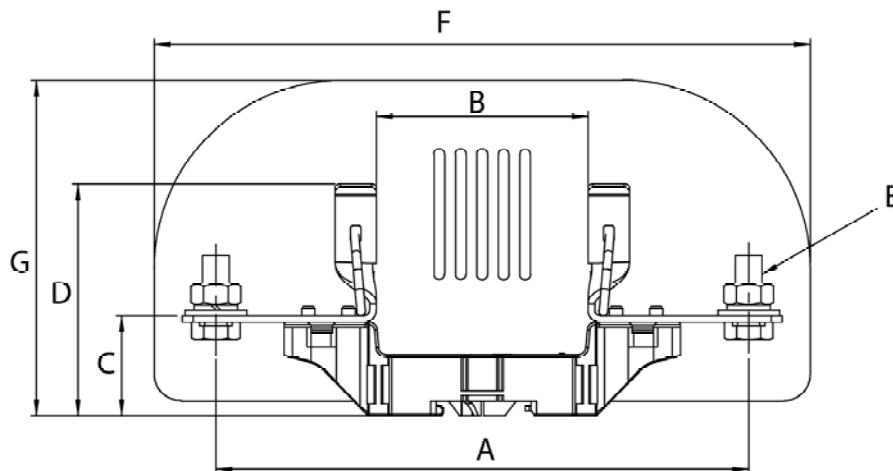

Catalogue numbers	NH Fuse link body size	A	B	C	D	E	F	G
SD1	NH1	175	79	37	78	M10 x 25	245	125.5
SD2	NH2	199	79	37.5	86	M10 x 25	245	125.5
SD3	NH3	209	82	37.5	88	M12 x 30	260	137.5

Data sheet: 720149

XL battery storage fuse links, BSF-3XL

Overview and technical data

XL battery storage fuse links, 250 to 500 A, 1500 V d.c., BSF-3XL

Description

Eaton's Bussmann series XL battery storage fuse links are specifically designed to protect and isolate battery array combiners and disconnects. These fuse links are capable of interrupting low overcurrents associated with faulted battery storage systems.

Fuse size

3L

Catalogue number

Knife blade fuse links: BSF-(amps)G-3XL15

Bolted fuse links: BSF-(amps)G-3XL15-B



Bolted fuse link

Technical data

- Rated voltage: 1500 V d.c.
- Rated current: 250 to 500 A
- Breaking capacity: 100 kA
- Class of operation: gBat proposed for full range fuse links for protection of battery storage systems
- Time constant: 4.5 ms at 100 kA

Standards/Approvals

- IEC 60269-7
- RoHS and REACH compliant

Packaging

MOQ: 3

Packaging 100% recyclable

Technical data

Catalogue number with knife blade	Catalogue number with bolted blade	Fuse body size	Rated current (Amps)	Rated voltage (V d.c.)	Pre-arcing I ² t	Total I ² t @ 1500 V d.c.	Power loss at 0.7 x I _n (W)	Power loss at I _n (W)
BSF-250G-3XL15	BSF-250G-3XL15-B	3	250	1500	74,000	263,000	20	49
BSF-315G-3XL15	BSF-315G-3XL15-B	3	315	1500	150,000	533,000	21	52
BSF-355G-3XL15	BSF-355G-3XL15-B	3	355	1500	195,000	693,000	24	59
BSF-400G-3XL15	BSF-400G-3XL15-B	3	400	1500	296,000	1,060,000	24	61
BSF-450G-3XL15	BSF-450G-3XL15-B	3	450	1500	412,000	1,470,000	27	67
BSF-500G-3XL15	BSF-500G-3XL15-B	3	500	1500	532,000	1,890,000	29	73

Compatible microswitches

Catalogue number	Fuse type	Fuse body size	Microswitches	Terminal size	Rated Voltage	Rated current
BSF-(amps)G-3XL15	Knife blade	3	170H0236	6.3 x 0.8 mm	250 V a.c.	5 A
			170H0238	2.8 X 0.5 mm	250 V a.c.	5 A
BSF-(amps)G-3XL15-B	Bolted blade	3	170H0069	6.3 x 0.8 mm	250 V a.c.	5 A

Compatible XL Bases for XL knife blade fuses only

Catalogue number	Fuse type	Fuse body size	NH Bases
BSF-(amps)G-3XL15	Knife blade	3	SD3L-S-PV (up to 400 A)

Outline drawing - 3L Bladed

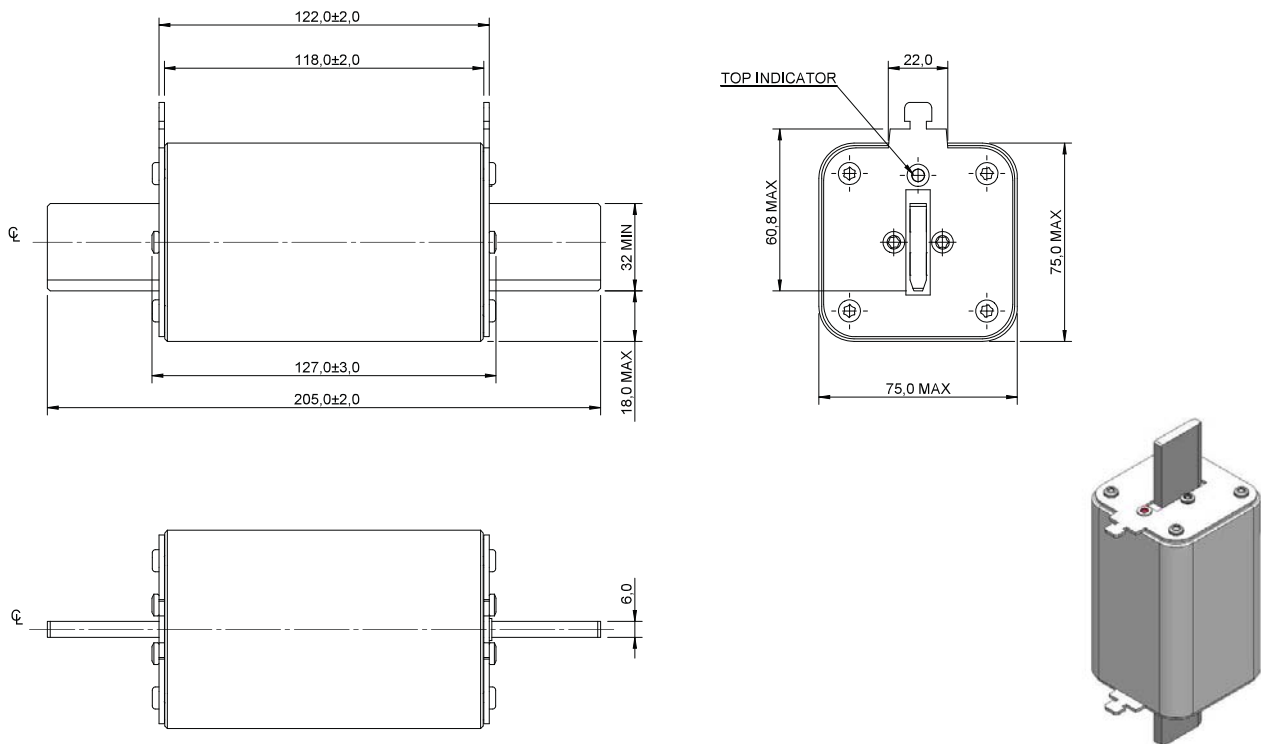

Outline drawing - 3L Bolted

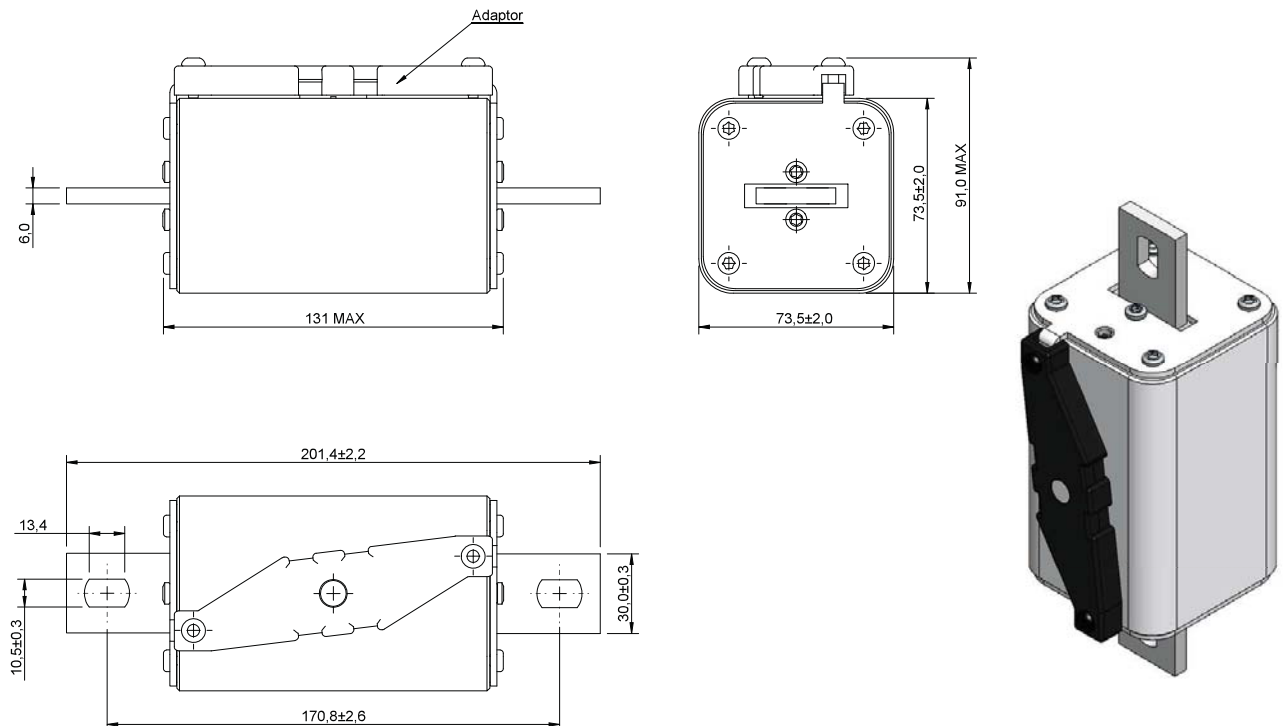

XL battery storage fuse links, BSF-3XL

Time-current curve and peak-let through curve

Time-current curve

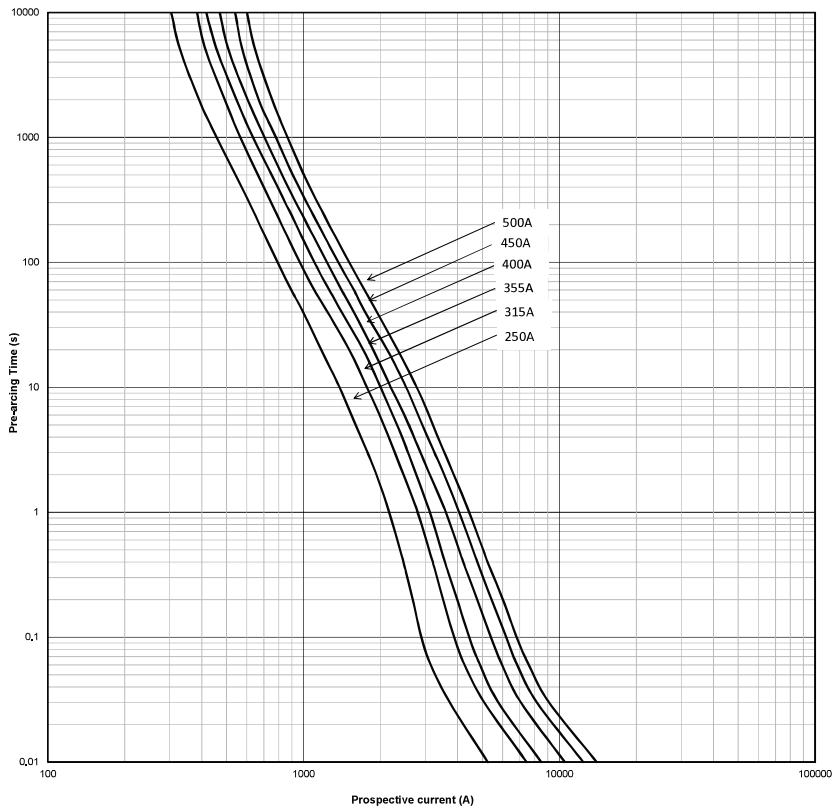

Peak let-through curve

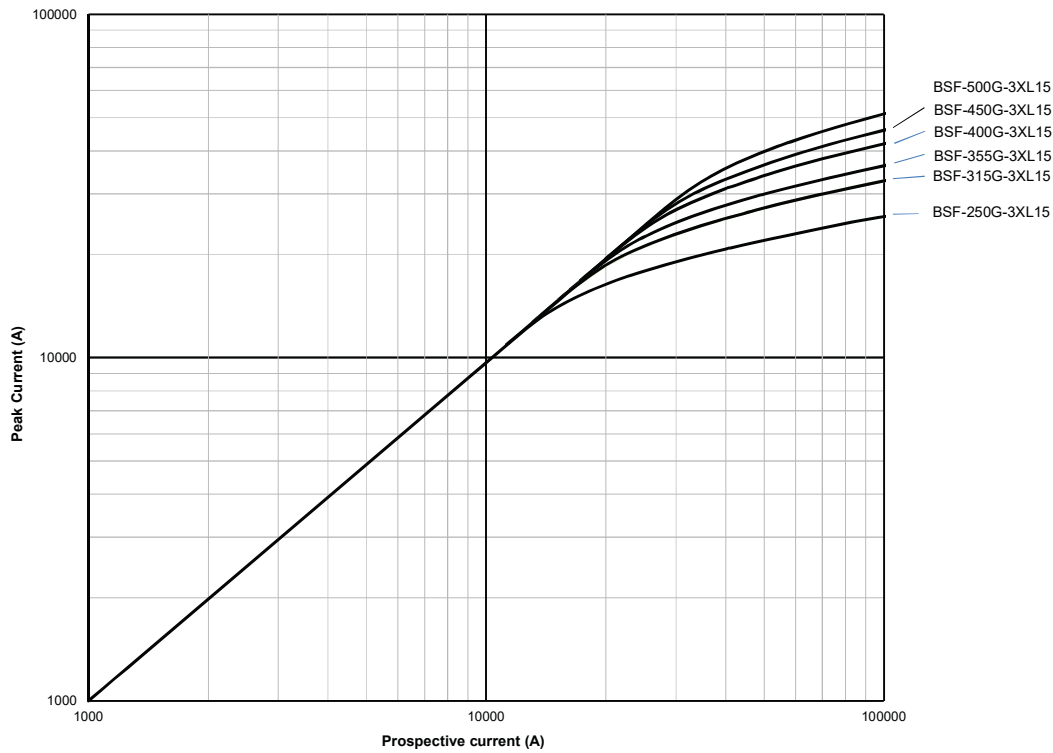

Catalogue number

SD3L-S-PV to fit 3L NH Battery storage fuse links

Technical data

- Rated voltage: 1500 V d.c.
- Rated current: 500 A
- Power acceptance (Watts): Size 3L: 108W
- Degree of protection level: IP20 with terminal covers in place and shielding of any exposed part of the terminal lugs
- Operating temperature range: -45°C to 80°C (with fuse link derating above 30°C)
- Screw mounting, dimensions and spacing of screw holes are shown on drawing and dimension
- Terminal/Lug mounting torque: 32N•m
- Fuse terminals mounting terminals: 12 N•m
- Silver plated copper fuse clips
- UL94 Flammability rating: base V-0, terminal cover V-0
- Glow wire test (IEC-695) 960°C
- Multiple poles can be configured with use of phase barrier accessory kit (SDsize-PB)
- Weight:SD3L-S-PV: 0.65 kg



Standards/Approvals

- IEC 60269-1
- UL Listed (file number E348242)

Packaging

MOQ: 1

Dimensions - mm

Catalogue numbers	XL Style fuse link size	Maximum fuse rated current (Amps)	Power acceptance	A	B	C	D	E	F	G	H	J
SD3L-S-PV	3L	500	108W	300	270	60	35	17.5	30	28	10.5	M12

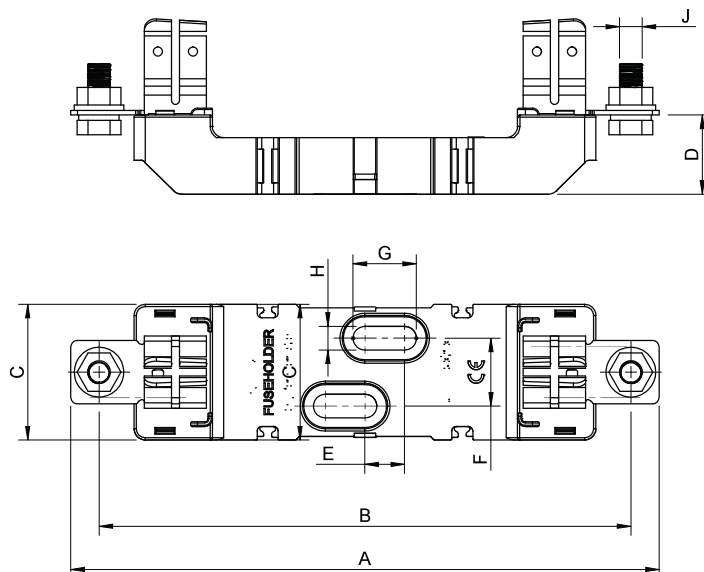

Contact details

Customer satisfaction team

Eaton's customer satisfaction team is available to answer questions regarding Eaton's Bussmann series products.

Europe calls can be made between:

Monday — Thursday 7.30 a.m. - 5.30 p.m. GMT

Friday 7.30 a.m. - 5.00 p.m. GMT

The customer satisfaction team can be reached via:

Phone: 00 44 (0) 1509 882 600

Fax: 00 44 (0) 1509 882 786

Email: GBBURsales@eaton.com

www.my.eaton.com

www.my.eaton.com supports the following product lines: B-Line series, Bussmann series, Crouse-Hinds series, Lighting solutions, Cooper Power series and Wiring devices.

Get started today at www.my.eaton.com by clicking 'Request User ID and Password'.

- Easy to Navigate
- Simple to Use
- Real-Time Data

Application engineering

Application engineering assistance is available to all customers. The application engineering team is staffed by university-qualified electrical engineers who are available with technical and application support.

European calls can be made between:

Monday — Thursday 8.30 a.m. - 4.30 p.m. GMT

Friday 8.30 a.m. - 4.00 p.m. GMT

Application engineering can be reached via:

Phone: 00 44 (0) 1509 882 699

Fax: 00 44 (0) 1509 882 794

General technical enquiries: buletechnical@eaton.com

High speed technical enquiries:
bulehighspeedtechnical@eaton.com

At Eaton, we're energized by the challenge of powering a world that demands more. With over 100 years experience in electrical power management, we have the expertise to see beyond today. From groundbreaking products to turnkey design and engineering services, critical industries around the globe count on Eaton.

We power businesses with reliable, efficient and safe electrical power management solutions. Combined with our personal service, support and bold thinking, we are answering tomorrow's needs today. Follow the charge with Eaton. Visit eaton.com/electrical.

Contact your local Eaton office

Electrical Sector
Eaton Electrical Products Limited
Unit 1, Hawker Business Park
Melton Road
Burton-on-the-Wolds
LE12 5TH
Leicestershire
United Kingdom
GBBURsales@eaton.com
www.eaton.com

Eaton
EMEA Headquarters
Route de la Longeraie 7
1110 Morges, Switzerland

Eaton Electrical Products Limited
Unit 1, Hawker Business Park
Melton Road,
Burton-on-the-Wolds
LE12 5TH
United Kingdom

© 2020 Eaton
All Rights Reserved
Printed in the United Kingdom
Publication No.ca135002en
June 2020

Changes to the products, to the information contained in this document, and to prices are reserved; so are errors and omissions. Only order confirmations and technical documentation by Eaton is binding. Photos and pictures also do not warrant a specific layout or functionality. Their use in whatever form is subject to prior approval by Eaton. The same applies to Trademarks (especially Eaton, Moeller, and Cutler-Hammer). The Terms and Conditions of Eaton apply, as referenced on Eaton Internet pages and Eaton order confirmations.

Eaton is a registered trademark.

All other trademarks are property of their respective owners.

Follow us on social media to get the latest product and support information.

