

KONTRAC PN225AC Converter for dynamic reactive power compensation

KONTRAC
PN225AC



KONTRAC PN225AC is a trackside converter which is used for dynamic reactive power compensation. It is used in substation facilities 110kV/25kV in which devices for fixed reactive power compensation have already been installed. The converter compensates variable amount of reactive power which can fluctuate considerably during a given time period. The range of compensated reactive power of each converter is from 225 kVAr capacitive to 225 kVAr inductive. If a higher range of compensated reactive power is needed, it can be accomplished by parallel connection of several converters. The input stage of the converter is made of robust components dimensioned for rolling stock converter applications which makes this converter KONTRAC PN225AC resistant to spikes, sags and surges that are likely to appear in overhead lines.

This proven and reliable technical solution enables significant energy savings, thus making it a perfect solution for sustainable development.

Features

- Rolling stock converter technology
- Robust input stage of converter
- Nearly sinusoidal current, in phase with the voltage
- Line friendly
- Latest IGBT technology
- Easy maintenance
- Modular design of power units
- Air cooling

KONTRAC PN225AC consists of

- Input contactors and precharging circuit
- Input filter
- Two input chokes
- Two four quadrant converters
- Two DC links with overvoltage protections
- Air ventilation system
- Control unit

KONTRAC PN225AC

Digital control unit

Digital control unit (DCU) is based on proprietary embedded control platform which has been used for years in our rail solutions (locomotives, coaches, trams, EMU, DMU). DCU is responsible for all sequence control, regulation, protection, communication, supervision and diagnostics tasks.

Diagnostic and visualization

Proprietary powerful diagnostic and visualization tool (ZZT) is compatible with all our platforms through many generations of control electronic solutions. Configurable event-driven data logging and event recording is integrated in the control electronics.

Mechanical design and cooling system

The converter has IP54 mechanical protection and it is designed for mounting inside the traction substations. The modular design of the power modules allows an easy maintenance. The converter is efficiently cooled by forced air.

Application examples

Two converters KONTRAC PN225AC are planned to be installed in substation Mrzlo polje in Croatia. Two other converters will be installed in substation Oštarije, also in Croatia. The converters will be used for dynamic reactive compensation in overhead lines. This proven and reliable technical solution enables significant energy savings which also has a positive effect on nature as well as on material costs.

BASIC TECHNICAL DATA

Input voltage	400 V, 50 Hz over transformer 25 kV / 400 V
Minimum input voltage	280 V (equivalent to 17,5 kV of overhead line voltage)
Maximum input voltage	480 V (equivalent to 29 kV of overhead line voltage)
Nominal power	± 225 kVAr
Cooling	Forced air-cooling
Size (W x D x H)	1200 x 800 x 2100 mm
Weight	700 kg
Mounting place	Substation
Connecting interface	CAN / Ethernet



Two converters KONTRAC PN225AC will be installed in Mrzlo polje, Croatia.

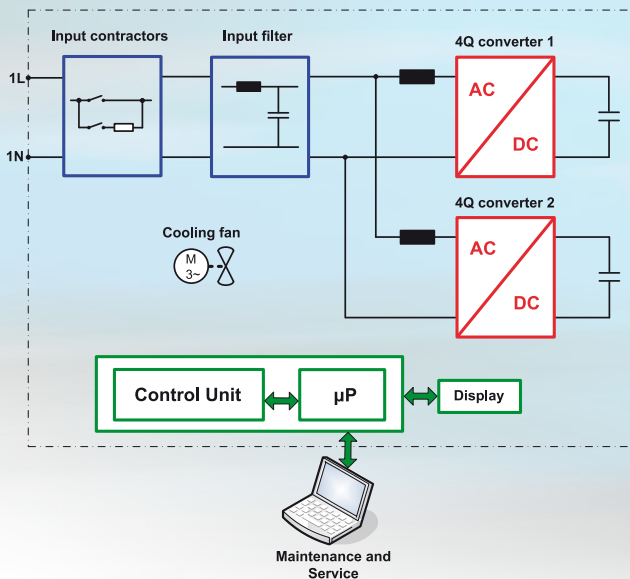

Block diagram of the converter

KONČAR

KONČAR - Electronics and Informatics Inc.

Fallerovo šetalište 22, 10000 Zagreb, Croatia
 phone: +385 1 3655 599; fax: +385 1 3655 298
 e-mail: transportation@koncar-inem.hr
 www.koncar-inem.hr