

Weight 500g

Device family	Clamp part number	clamp force	T _{JMAX}	Maximum allowed height	Outline
		kgf	°C	mm	
Pulse Thyristors (Y) and GTO Thyristors (G, H & S) NC Housing	XK2100SA076ML	2100	125	54	WC20
	XK2100DA076ML			67	WC21
	XSK2200Dx075M038	2200	190	38	WC61-WC63
	XSK2200Dx075M044			44	
	XSK2200Dx075M050			50	
	XSK2200Dx075M057			57	
	XSK2200Dx075M063			63	
	XSK2200Dx075M069			69	
	XSK2200Dx075M076			76	
	XSK2200Dx075M082			82	
	XSK2200Dx075M088			88	
	XSK2200Dx075M095			95	
	XSK2200Dx075M101			101	
	XSK2200Dx075M107			107	
	XSK2200Dx075M114			114	
XSK2200Dx075M120	120				

XK2100S/DA076ML

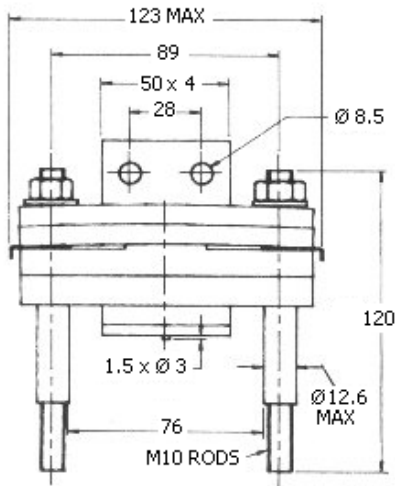

WC20 – SA Style

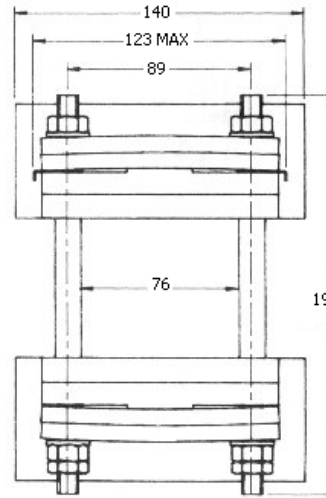
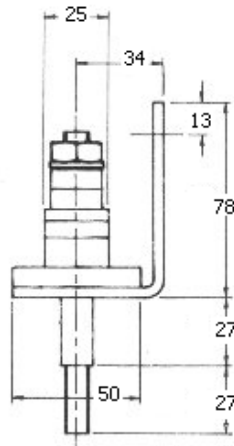

WC21 – DA Style

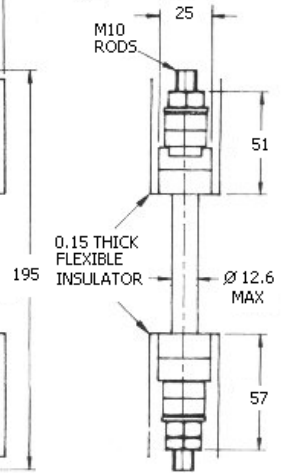

XSK2200Dx075

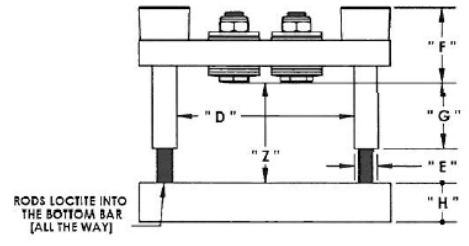
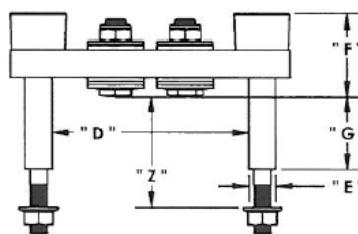
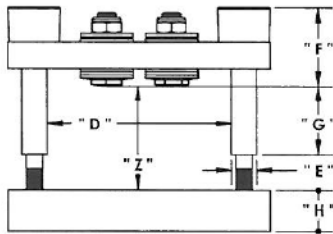
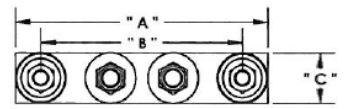
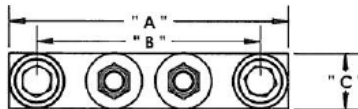
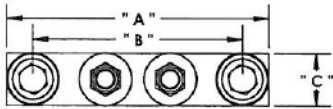

WC61 – DA Style

WC62 – DT Style

WC63 – DF Style

Dimensions (mm)

- A – 112.78
- B – 89.00
- C – 25.40
- D – 75.00
- H – 12.70

Part #'s	" Z " min	" Z " max	00900	01500	02200
XSK xxxxx xx 075 M 038	31.75	38.10	19.55	26.16	24.63
XSK xxxxx xx 075 M 044	38.10	44.45	22.35	29.21	27.68
XSK xxxxx xx 075 M 050	44.45	50.80	25.40	32.25	30.73
XSK xxxxx xx 075 M 057	50.80	57.15	28.44	34.79	33.52
XSK xxxxx xx 075 M 063	57.15	63.50	31.49	38.10	36.57
XSK xxxxx xx 075 M 069	63.50	69.85	35.54	42.14	39.62
XSK xxxxx xx 075 M 076	69.85	76.20	37.33	43.18	41.65
XSK xxxxx xx 075 M 082	76.20	82.55	40.38	47.24	45.72
XSK xxxxx xx 075 M 088	82.55	88.90	43.43	50.29	48.51
XSK xxxxx xx 075 M 095	88.90	95.25	45.46	53.34	51.56
XSK xxxxx xx 075 M 101	95.25	101.60	49.53	56.13	54.61
XSK xxxxx xx 075 M 107	101.60	107.95	52.57	59.18	57.65
XSK xxxxx xx 075 M 114	107.95	114.30	55.37	62.23	60.70
XSK xxxxx xx 075 M 120	114.30	120.65	58.42	65.27	63.75

Force [kgf]	" E "	" F " (ref)	Bolt Type
900	12.19	40.55	M8
1500	12.19	35.79	M8
2200	12.19	37.37	M8