



RECTIFIERS

The Custom Power Specialist

BOX CLAMPS Series BX75

DESCRIPTION

GD Rectifiers Ltd produce a range of large disc cell clamping devices, specially developed for single side applications of commonly used press pack semiconductors.

Suitable for single side cooling, Stick stacks using multiple series devices, and some rotating applications.

Materials and components used in the manufacturing of these clamps are carefully selected and quality controlled, to ensure the compliance with the requested specifications.

BX series are normally supplied with a specific preset clamping force, to allow an easy and accurate clamping with no special tools.

The user should specify semiconductor thickness and clamping force value.

HOW TO ORDER

BX75 – (X) – (Y) – (Z),

Where X specifies, Busbar connection thickness (mm), Y the calibration force (kN), and Z, the cell height (mm). e.g. BX75–6–24–26

TECHNICAL CHARACTERISTICS

Dimensions see figures below, Clamping force up to 30 kN \pm 10%

Insulation Material FR4 Glass Laminate, UL94 V-0. Operating Temp. Range -40°C - +140°C

Dielectric Strength 6kV+ rms 50Hz

Semiconductor Diameter 75mm max. Semiconductor Thickness 20 to 40mm typ.

Weight 1000g approx. Fixing Screws supplied with Clamp.

Special designs are available on request; please contact GD Rectifiers Ltd for details.

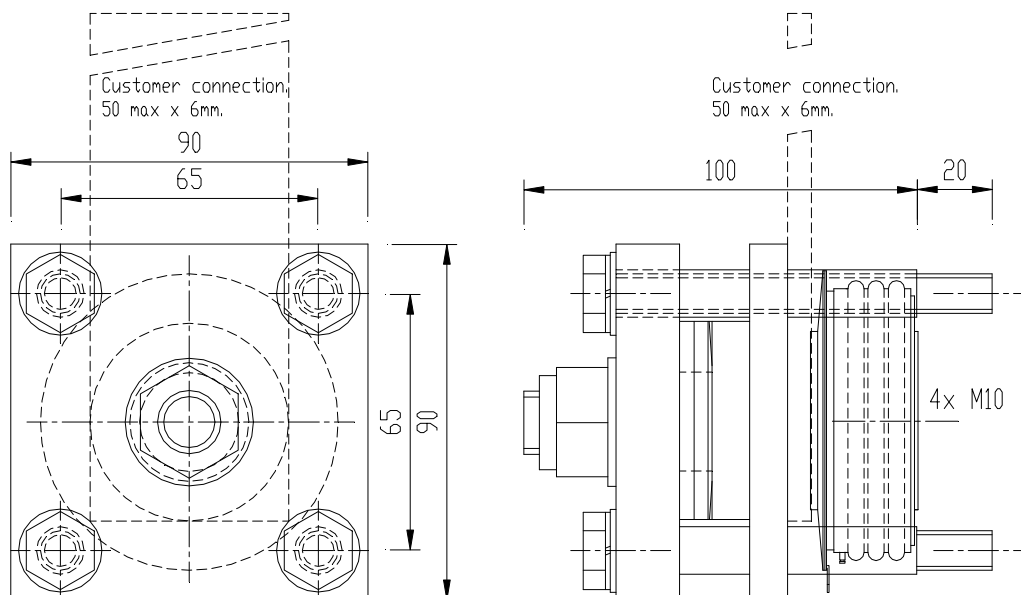

GD Rectifiers Ltd Bentley House, 2 William Way, Burgess Hill, West Sussex RH15 9AG

Tel: 01444 243452 Fax: 01444 870722 E-Mail: enquiries@gdrectifiers.co.uk