

**DESCRIPTION**

GD Rectifiers Ltd produce a range of large disc cell clamping devices, specially developed for double side applications of commonly used press pack semiconductors.

Materials and components used in the manufacturing of these clamps are carefully selected and quality controlled, to ensure compliance with the requested specifications.

BC series are normally supplied with a specific preset clamping force, to allow an easy and accurate clamping with no special tools.

The user should specify Clamping force (kN), & Pack height total.

**HOW TO ORDER**

BCxxD/LD – (Y) – (Z),

Where Y = the calibration force (kN), And Z, the Pack height (mm). e.g. BC89D –12–40

**TECHNICAL CHARACTERISTICS**

Dimensions see figures below, Clamping force up to 32 kN ± 10%

Insulation Material Noryl , UL94 V-0.

Operating Temp. Range -30°C - +110°C. Storage -40°C - +110°C. (200°C also available)

Insulation Voltage 3kVrms 1 min, 50Hz.

Semiconductor Diameter = A – F max. Semiconductor Thickness 14 to 40mm typ.

Weight BC54D=250g 79D=950g 89D=1250g 118D=1800g approx. Fixing Screws supplied with Clamp.

Special designs are available on request; please contact GD Rectifiers Ltd for details.

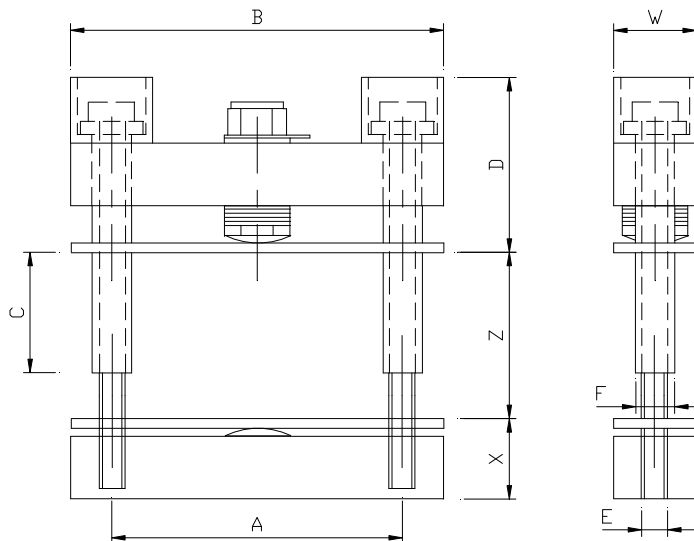

PT No	Dimensions approx								Pack Height typ		KN
	A	B	C	D	E	F	W	X	Z min	Z max	max
BC54D	54	70	50	32	M6	9	15	15	30	90	6
BC79D	79	104	45	62	M8	12	25	28	30	90	20
BC79LD	79	104	70	62	M8	12	25	28	30	90	20
BC89D	89	115	45	62	M8	12	25	28	30	90	20
BC89LD	89	115	70	62	M8	12	25	28	30	90	20
BC118LD	118	145	38	71	M8	12	25	35	40	90	32

DIMENSION "C" VARIABLE BY CUTTING BOLT INSULATOR TO SUIT.