



RECTIFIERS

The Custom Power Specialist

SPRING BAR CLAMPS – SBC132DV series

DESCRIPTION

GD Rectifiers Ltd produce a range of large disc cell clamping devices, specially developed for double side applications of commonly used press pack semiconductors.

Materials and components used in the manufacturing of these clamps are carefully selected and quality controlled, to ensure the compliance with the requested specifications.

SBC series are normally supplied with a specific preset clamping force, to allow an easy and accurate clamping with no special tools.

The user should specify Clamping force (kN), & Pack height total.

HOW TO ORDER

SBC132DV – (Y) – (Z),

Where Y = the calibration force (kN),

And Z, the Pack height (mm). e.g. SBC132DV –20–40

TECHNICAL CHARACTERISTICS

Dimensions see figures below, Clamping forces 20kN, 30kN, & 40kN \pm 10%

Insulation Material Attamica-H, Operating Temp. Range -40°C - +190°C. Storage -40°C - +190°C.

Insulation Voltage 6kVrms 1 min, 50Hz.

Semiconductor Diameter = 118mm max. Semiconductor Thickness 14 to 40mm typ.

Weight SBC132DV=1400g approx. Fixing Screws supplied with Clamp.

Special designs are available on request; please contact GD Rectifiers Ltd for details.

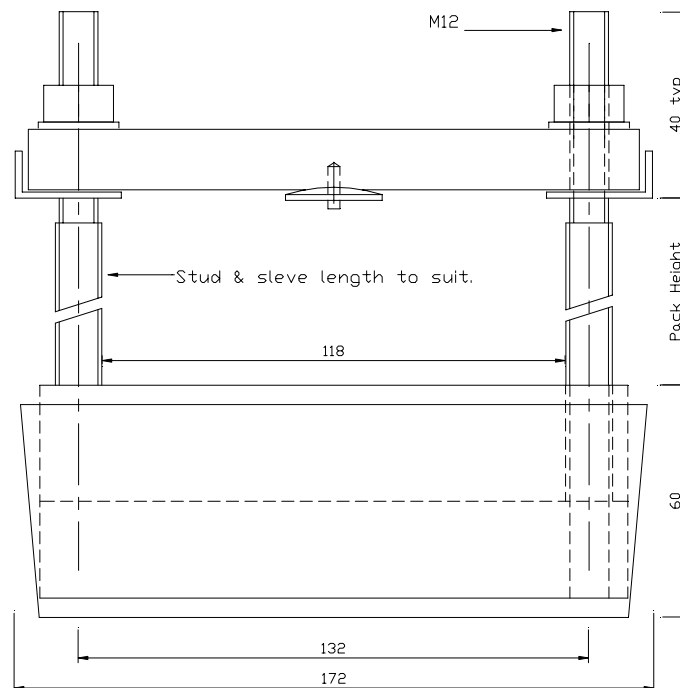

GD Rectifiers Ltd. Victoria Gardens, Burgess Hill, West Sussex RH15 9NB.

Tel: 01444 243452 Fax: 01444 870722 E-Mail: enquiries@gdrectifiers.co.uk