

DESCRIPTION

GD Rectifiers Ltd produce a range of large disc cell clamping devices, specially developed for double side applications of commonly used press pack semiconductors.

Materials and components used in the manufacturing of these clamps are carefully selected and quality controlled, to ensure compliance with the requested specifications.

BC series are normally supplied with a specific preset clamping force, to allow an easy and accurate clamping with no special tools.

The user should specify Clamping force (kN), & Pack height total.

HOW TO ORDER

BCxxS/LS – (Y) – (Z),

Where Y = the calibration force (kN),

And Z, the Pack height (mm). e.g. BC89S –12–40

TECHNICAL CHARACTERISTICS

Dimensions see figures below, Clamping force up to 32 kN ± 10%

Applications require rigid heatsink or base for mounting.

Insulation Material Noryl , Operating Temp. Range -30°C - +110°C. Storage -40°C - +110°C. (200°C also available)

Insulation Voltage 3kVrms 1 min, 50Hz.

Semiconductor Diameter = A – F max. Semiconductor Thickness 14 to 40mm typ.

Weight BC54S=150g 79S=600g 89S=800g 118S=1000g approx. Fixing Screws supplied with Clamp.

Special designs are available on request; please contact GD Rectifiers Ltd for details.

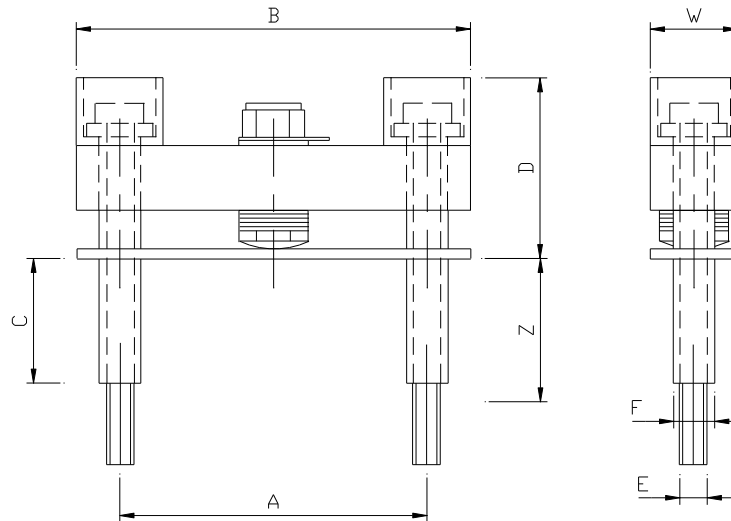

PT No	Dimensions approx							Pack Height typ		KN
	A	B	C	D	E	F	W	Z min	Z max	
BC54S	54	70	50	32	M6	9	15	30	90	6
BC79S	79	104	45	62	M8	12	25	30	90	20
BC79LS	79	104	70	62	M8	12	25	30	90	20
BC89S	89	115	45	62	M8	12	25	30	90	20
BC89LS	89	115	70	62	M8	12	25	30	90	20
BC118LS	118	145	38	71	M8	12	25	40	90	32

DIMENSION "C" VARIABLE BY CUTTING BOLT INSULATOR TO SUIT.